

Description: PLYFAST® DOUBLE LOCK NAIL consists of a precision formed tube and disk made from coated steel to prevent corrosion. The tube is shaped to easily penetrate decking and existing membranes. The disk is 2.7" in diameter and is securely clamped to the tube and rib reinforced to resist cupping. Locking Staple: Precision formed from stainless steel wire. It is available in lengths of 1.4", 1.8", 2.8", 3.8" and 4.8". PlyFast® Double Lock Nail Fastener is also Factory Mutual approved (1.8" – 4.8")

Use: Designed to attach base sheet, recovery board, and insulation to lightweight insulating concrete, structural wood fiber, and poured gypsum roof decks.

Corrosion Coating: Coated steel exhibits less than 15% red rust which meets or exceeds FM 4470 corrosion standards and withstands 30 cycles of the Kesternich DIN 50018 SFW 2.0 test.

Application: Always use PlyFast® Double Lock Drivers or other compatible Loc driver to install the fasteners. Consult manufacturer for the specific driver for your application. **Method:** Drive PlyFast® Double Lock Nail perpendicular to roof deck, seating cap flush with roofing surface. Once tube is set, drive the locking staple into the tube/disk unit until the top of the staple is flush with the cap (see illustration). **Operation:** When locking staple is driven, its dual wire legs diverge, anchoring the fastener in place (see illustration). Uplift resistance may vary depending on the density and integrity of the substrate.

Tools: For best installation result, use PlyFast® Double Lock Drivers or other compatible Loc driver. See PlyFast® Fastener Information Guide for specific details.

Approvals: PlyFast® Double Lock Nail Fastener is listed or approved with Factory Mutual (FM). Contact U.S. Ply, Inc. for specific/applicable codes.

Fastening Pattern: Consult U.S. Ply Technical Department and/or Factory Mutual requirements for recommended patterns in normal, exposed, and high wind velocity areas.

Product Data: PLYFAST® Double Lock Nail Fastener (typical)

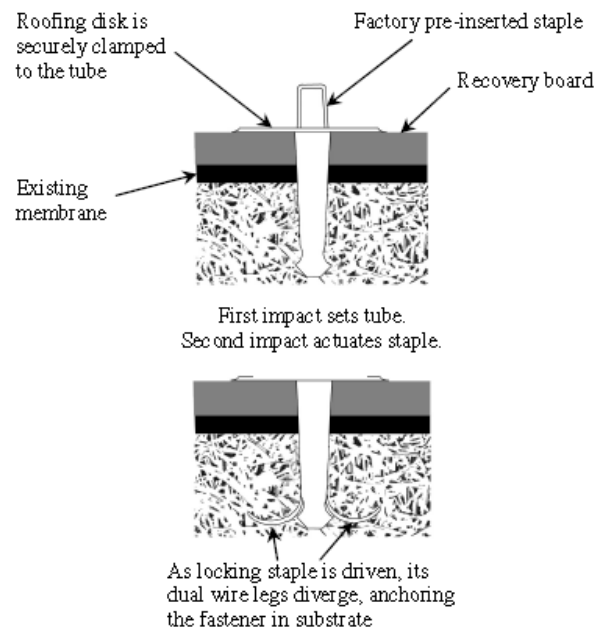
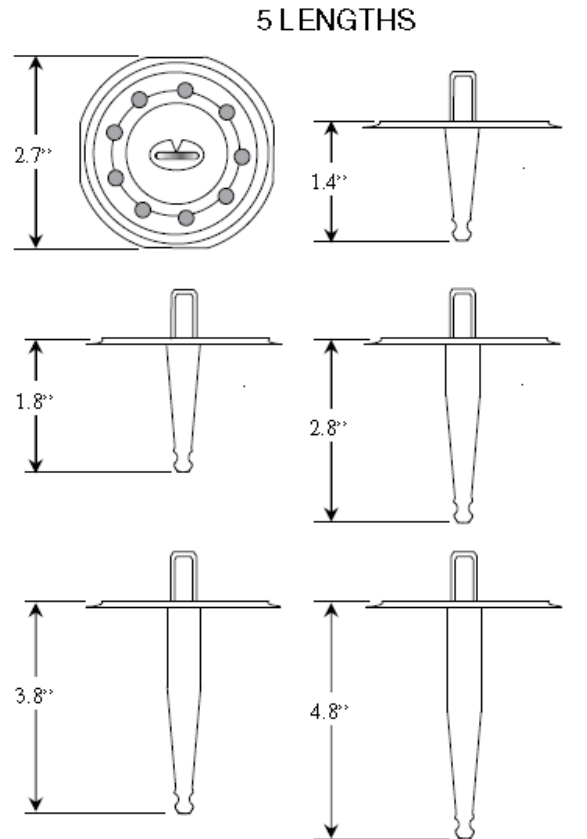

**PROUDLY
MADE IN THE U.S.A.**

CORPORATE HEADQUARTERS: P.O. BOX 1182, BRIDGEPORT, TEXAS 76426

PHONE: (817)413-0103 FAX: (817)413-8221

WWW.USPLY.COM

REV MAY 2023

Product Data: PLYFAST® Ordering Information (typical):

Product	Screw Length*	Pieces/Box	Weight/Box
1.4 Double Lock Nail-E	1.4"	500	26 lbs
1.8 Double Lock Nail-E	1.8"	500	28 lbs
2.8 Double Lock Nail-E	2.8"	500	34 lbs
3.8 Double Lock Nail-E	3.8"	500	42 lbs
4.8 Double Lock Nail-E	4.8"	250	27 lbs

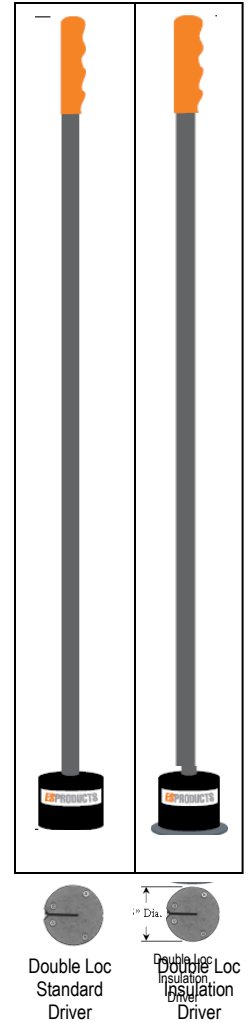

All values given are approximate and are subject to change without notice. There is no implied or express warranty given through these values or statements, nor are there any assertions that the product purchased has been individually tested to conform to these standards. Testing is performed on a random basis by “in-house” and independent “third party” evaluation for the purpose of classification and or approval. Acceptance, purchase and selection of these products are the sole responsibility of the buyer or buyer’s representative. We assume no responsibility for coverage, performance or injuries resulting from use. Liability, if any, is limited to replacement of the product. NO OTHER WARRANTY OR GUARANTEE OF ANY KIND IS MADE BY U.S. PLY, INC. EXPRESSED OR IMPLIED; STATUTORY, BY OPERATION OF LAW, OR OTHERWISE, INCLUDING MERCHANTABILITY AND FITNESS FOR A PARTICULAR PURPOSE.

