



All Weather Roofing Products
INSTALLATION GUIDE



APP & SBS Contractor Grade Materials

TABLE OF CONTENTS

Product Information

The Benefits of Modified Bitumen.....	2
All Weather APP Membranes.....	2
All Weather SBS Membranes.....	3
Base Sheets.....	3
Ply Sheets.....	3
Asphalt.....	3
Adhesives, Cements, Coatings & Primer.....	4
Generic Insulation Types.....	4
Insulation Adhesive.....	4
Fasteners.....	4
Surfacings & Walkways.....	5

General Information

Introduction.....	6
Design and Construction.....	6
Specifications.....	6
Service.....	6
Handling and Storage.....	6
Building Code.....	7
Fire Resistance.....	7
Wind Resistance.....	8
Roof Decks.....	8
Steel Decks.....	8
Poured Structural Concrete.....	9
Precast Concrete.....	9
Pre-stressed Concrete.....	9
Lightweight and Cellular Concrete.....	9
Poured Gypsum.....	10
Wood Plank Decks.....	10
Plywood Decks.....	11
Oriented Strand Board – Waferboard.....	11
Structural Wood Fiber Decks.....	11
Vapor Retarders.....	12
The Case for the use of a Vapor Retarder.....	12
The Case against the use of a Vapor Retarder.....	12
Recovering Existing Roofs.....	13

Warranty Information

All Weather Limited Material Warranty.....	13
Exclusions.....	14
Exceptions.....	14
Inspections.....	15

Application Information

Insulation Application.....	15
Insulation Attachment to Nailable Substrates.....	16
Insulation Attachment to Non-Nailable Substrates.....	16
Insulation Attachment – Low Rise Foam Adhesive.....	16
Coverboard Requirements.....	16
Base Sheet Application.....	17
All Weather APP Membrane Application.....	18
All Weather SBS Membrane Application.....	18
Safety Precautions / Considerations.....	19
Torch Safety Information.....	19
Cold Weather Precautions.....	20
Membrane Flashing Application.....	20
Sheet Metal.....	21
Surfacing Application.....	22
Walkways.....	22

Specification Information

All Weather APP Specification Index.....	23
All Weather SBS Specification Index.....	23
All Weather Specification Key.....	24
All Weather Zone Map.....	24
All Weather APP Specification Plates	
AW APP – 2 Ply Nailable Deck/Lightweight Concrete Deck.....	25
AW APP – 2 Ply Insulated Deck.....	26
AW APP – 1 Ply Non-Nailable Deck.....	27
AW APP – 3 Ply Nailable Deck/Lightweight Concrete Deck.....	28
AW APP – 3 Ply Insulated Deck.....	29
AW APP – 2 Ply Non-Nailable Deck.....	30
AW APP – 1 Ply Existing Smooth Surface Recover.....	31
AW APP – 2 Ply Existing Smooth Surface Recover.....	31
AW APP – 3 Ply Existing Smooth Surface Recover.....	32
AW APP – 2 Ply Existing Gravel Surface Recover.....	33
AW APP – 3 Ply Existing Gravel Surface Recover.....	34
All Weather SBS Specification Plates	
AW SBS – 2 Ply Nailable Deck/Lightweight Concrete Deck.....	35
AW SBS – 2 Ply Insulated Deck.....	36
AW SBS – 2 Ply Non-Nailable Deck.....	37
AW SBS – 2 Ply Existing Smooth Surface Recover.....	38
AW SBS – 2 Ply Existing Gravel Surface Recover.....	39

All Weather APP Flashing Details

All Weather APP Detail 1 – Perimeter Gravel Edge.....	40
All Weather APP Detail 2 – Perimeter Drip Edge.....	40
All Weather APP Detail 3 – Parapet Wall Flashing – 24” & under.....	40
All Weather APP Detail 4 – High Parapet Wall – Over 24”.....	40
All Weather APP Detail 5 – Roof Drain.....	40
All Weather APP Detail 6 – Pitch Pan Flashing.....	40
All Weather APP Detail 7 – Pre-manufactured Curb Flashing.....	41
All Weather APP Detail 8 – Expansion Joint.....	41
All Weather APP Detail 9 – Vent Stack Flashing.....	41
All Weather APP Detail 10 – Roof Projection.....	41
All Weather APP Detail 11 – Scupper Flashing.....	41
All Weather APP Detail 12 – Flat Roof / Shingle Tie-in.....	41

All Weather SBS Flashing Details

All Weather SBS Detail 1 – Perimeter Gravel Edge.....	42
All Weather SBS Detail 2 – Perimeter Drip Edge.....	42
All Weather SBS Detail 3 – Parapet Wall Flashing – 24” & under.....	42
All Weather SBS Detail 4 – High Parapet Wall – Over 24”.....	42
All Weather SBS Detail 5 – Roof Drain.....	42
All Weather SBS Detail 6 – Pitch Pan Flashing.....	42
All Weather SBS Detail 7 – Pre-manufactured Curb Flashing.....	43
All Weather SBS Detail 8 – Expansion Joint.....	43
All Weather SBS Detail 9 – Vent Stack Flashing.....	43
All Weather SBS Detail 10 – Roof Projection.....	43
All Weather SBS Detail 11 – Scupper Flashing.....	43
All Weather SBS Detail 12 – Flat Roof / Shingle Tie-in.....	43

PRODUCT INFORMATION

All Weather modified bitumen membranes are offered in two durable varieties which give our roofing systems the advantage. The membrane consists of either a strong glass fiber or a nonwoven polyester core which is impregnated on both sides with our custom blended modified bitumen.

Raw materials are inspected and tested before final acceptance to ensure proper quality of the finished product. The result is a quality modified bitumen membrane that demonstrates outstanding waterproofing characteristics, extreme heat resistance and flexibility in low and extreme temperatures. It is what makes our roofs stand up to the test of time.

THE BENEFITS OF MODIFIED BITUMEN

Modified bitumen membranes are designed for buildings with low-slope or “flat” roof structures. Engineered modified bitumen roofing membranes originated in Europe in the mid 1960’s and have been used successfully in the United States since the late 1970’s.

The name modified bitumen is attributed to a process in which the select asphalt is “modified” by blending certain synthetic polymers which are also known as “modifiers”. The blending process modifies the asphalt to provide certain physical characteristics that are extremely important for a roofing membrane such as increased resistance to brittleness at cold temperatures, greater flow resistance at high temperatures, and increased elasticity.

Modified bitumen roof systems are differentiated in two types of modifiers used: Atactic-Polypropylene (APP) and Styrene-Butadiene-Styrene (SBS). Both membrane types are also reinforced with either glass or polyester and further finished with either a smooth or mineral surfacing. APP and SBS membrane differ in how they are installed on the roof. All Weather APP is always installed utilizing the torch method and All Weather SBS is installed primarily with hot asphalts or a compatible cold adhesive (see data sheets and/or this installation guideline manual for specific application methods).

All Weather membranes are designed to unroll straighter and lay flatter making them easy to handle reducing down time, allowing for faster installation, and helping you achieve a better bottom line and giving the roofing professional what they want and need out of a quality product.

All Weather membranes have the following characteristics:

- Superior impermeability to water
- Flexibility at low temperatures
- High resistance to thermal degradation
- Greater tensile and tear resistance, elongation which helps to accommodate certain building movements
- With insulation, provides an even better-performing building component
- Broad range of application methods: (APP) torch method;
- (SBS) hot asphalts, cold adhesives or hot air seaming with cold adhesive.
- Top surfacing options – smooth for reflective coating application or granule option for color design aesthetics.
- Better resistance against foot traffic and common rooftop abuse when needed

ALL WEATHER APP MEMBRANES

All Weather APP membranes contain modified bitumen compounds that are made by blending select grades of non-blown asphalt with quality APP (Atactic Polypropylene) thermoplastic polymers. The result is a modified bitumen membrane with waterproofing characteristics far superior to standard asphalt blends.

All Weather APP membranes are manufactured in rolled sheets and contain a polypropylene and/or polyethylene film on the underside to prevent roll blocking. These membranes are applied using heat welding techniques. The film backing provides a visual indicator for proper welding temperatures as the film will melt, allowing the APP modified bitumen compound to adhere to itself and the substrate that it is applied to.

The only tools required for application of the All Weather APP membranes are a propane gas roofing torch, a rounded tip roofer’s trowel, a hook blade utility knife, a roofer’s roll hook and a weighted seam roller. A fire extinguisher and fire resistant gloves are also necessary for safety precautions.

ALL WEATHER #85 GM FIBERGLASS CAP is a mineral surfaced modified bitumen cap sheet designed for use in modified bitumen roof membrane systems or with conventional roofing plies in a hybrid configuration. All Weather APP consists of a fiberglass mat impregnated and coated with Atactic polypropylene (APP) modified bitumen.

It is the cap ply of multiple ply roofing systems, or the base ply in a two ply modified bitumen assemblies. It is applied with 3-inch side laps and 6-inch end laps.

Each roll is approximately 3.28’ x 33’ (1m x 10m) Thickness, 3.4 mm (135 mils). Roll weight is approximately 85 lbs (38.5 kg). For more information see product data.

Note: All Weather APP #85 GM Fiberglass Cap is limited to Zone 2 only.

ALL WEATHER APP 190 SMOOTH is a smooth surfaced modified bitumen base/inter-ply/cap sheet designed for use in modified bitumen roof membrane systems or with conventional roofing plies in a hybrid configuration. All Weather APP 190 Smooth consists of a non-woven polyester mat impregnated and coated with Atactic polypropylene (APP) modified bitumen.

It can act as a base-ply/inter-ply/cap-ply of a multiple ply roofing systems or hybrid BUR/ modified bitumen assemblies. It is applied with 3-inch side laps and 6-inch end laps. All Weather APP 190 Smooth must be applied using heat welding (torch) techniques.

Each roll is approximately 3.28’ x 33’ (1m x 10m) Thickness, 3.4 mm (135 mils). Roll weight is approximately 84 lbs (38 kg). For more information see product data.

ALL WEATHER APP 190 GRANULATED is a mineral surfaced modified bitumen cap sheet designed for use in modified bitumen roof membrane systems or with conventional roofing plies in a hybrid configuration. All Weather APP 190 Granulated consists of a non-woven polyester mat impregnated and coated with Atactic polypropylene (APP) modified bitumen.

It is the cap ply of multiple ply roofing systems, or the cap ply in hybrid BUR/modified bitumen assemblies. It is applied with 3-inch side laps and 6-inch end laps. All Weather APP 190 Granulated must be applied using heat welding (torch) techniques.

Each roll is approximately 3.28' x 33' (1m x 10m) Thickness, 3.8 mm (150 mils). Roll weight is approximately 98 lbs (44.45 kg). For more information see product data.

ALL WEATHER SBS MEMBRANES

All Weather SBS membranes contain a modified bitumen compound that is made by blending select grades of non-blown asphalt with quality SBS (Styrene Butadiene Styrene) elastomeric polymers. The result is a modified bitumen compound with superior waterproofing characteristics far superior to standard asphalt blends.

All Weather SBS membranes are manufactured in rolled sheets and come with factory applied granule surfacing on the top side and fine mineral surfacing on the underside to prevent roll blocking. These membranes are applied using either hot asphalt or a compatible cold adhesive.

For hot asphalt applied systems, installation is performed with the use of ASTM D312 Type III or IV roofing asphalt and is applied using conventional hot asphalt mopping techniques with conventional hot asphalt equipment.

For cold adhesive applied systems, installation is performed with USP® 901 modified bitumen adhesive or other All Weather approved modified bitumen adhesive. The adhesive is applied achieving a uniform adhesive bead to the edge of the seam to ensure that the seam is completely sealed. As an alternative, the seam may be welded together using a propane detail torch or an automatic hot-air welding device that is designed for modified bitumen seam welding.

Whether the All Weather SBS membrane is installed in by hot asphalt mopping, SBS modified adhesive or using a combination of adhesive with welding the seam, each application method is designed to give you a solid seam that lasts.

ALL WEATHER SBS #85 GM FIBERGLASS CAP is a mineral surfaced modified bitumen cap sheet designed for use in modified bitumen roof membrane systems or with conventional roofing plies in a hybrid configuration. All Weather SBS Glass Cap consists of a fiberglass mat impregnated and coated with Styrene-Butadiene-Styrene (SBS) modified bitumen.

It is the cap ply of multiple ply roofing systems, or the cap ply in hybrid BUR/modified bitumen assemblies. It is applied with 4-inch side laps and 6-inch end laps.

Each roll is approximately 3.28' x 33' (1m x 10m) Thickness, 3.4 mm (135 mils). Roll weight is approximately 85 lbs (38.5 kg). For more information see product data.

ALL WEATHER SBS 190 GRANULATED is a mineral surfaced modified bitumen cap sheet designed for use in modified bitumen roof membrane systems or with conventional roofing plies in a hybrid configuration. All Weather SBS 190 Granulated consists of a non-woven polyester mat impregnated and coated with styrene-butadiene-styrene (SBS) modified bitumen.

It is the cap ply of multiple ply roofing systems, or the cap ply in hybrid BUR/modified bitumen assemblies. It is applied with 4-inch side laps and 6-inch end laps. All Weather SBS 190 Granulated can be applied in hot asphalt or cold adhesive.

Each roll is approximately 3.28' x 33' (1m x 10m) Thickness, 3.8 mm (150 mils). Roll weight is approximately 98 lbs (44.45 kg). For more information see product data.

BASE SHEETS

Fiberglass Base Sheet - ASTM D4601: Standard Specification for Asphalt Coated Glass Fiber Base Sheet Used in Roofing. A general purpose, glass fiber reinforced base sheet compatible with torch applied, cold adhesive applied and hot asphalt applied membranes. May be mechanically attached to nailable decks, solid mopped to approve insulations and to non-nailable decks where appropriate.

Vented Base Sheet - ASTM D4897 Type II: Standard

Specification for Asphalt-Coated Glass-Fiber Venting Base Sheet Used in Roofing. A glass fiber reinforced base sheet with a mineral surfacing on the underside of the sheet, designed specifically to provide positive venting of trapped pressure gasses. May be mechanically attached to nailable decks. Can be used in all specifications requiring a mechanically fastened base sheet. Particularly suited for use over existing smooth roofs in recover applications and over lightweight and poured gypsum decks.

PLY SHEETS

Type IV Glass Ply Sheet - ASTM D2178 Type IV: Standard

Specification for Asphalt Glass Felt Used in Roofing and Waterproofing. A general purpose, glass fiber reinforced ply sheet designed for use in multiple construction of hot asphalt applied roof systems. Designed to be solid mopped to approve insulations and approved base sheets where appropriate.

Type VI Glass Ply Sheet - ASTM D2178 Type VI: Standard Specification for Asphalt Glass Felt Used in Roofing and Waterproofing. A heavyweight, glass fiber reinforced ply sheet designed for use in multiple construction of hot asphalt applied roof systems. Designed to be solid mopped to approve insulations and approved base sheets where appropriate.

ASPHALT

All Weather Roofing systems require the use of ASTM D312, Type III or Type IV asphalt for the application of roof insulation, roof tape, base, ply, cap membranes and surfaced aggregate for slopes as referenced in the table below.

Specification and use of low softening point bitumen increases the opportunity for bitumen drippage and membrane slippage. The designer and roofing contractor must take any necessary precautions to prevent damage to the structure or interior due to bitumen drippage.

ASTM D312 TYPE	Asphalt Softening Point	Maximum Slope
III	185°F -205°F 85°C-90°C	Up to ½" per foot (4.2 cm/m)
IV	210°F-225°F 99°C-102°C	Up to 3" per foot (25 cm/m)

Asphalt Grades for Standard Built-Up Roofing Felts

Steep or Special Steep grade (Type III or IV) asphalt or SEBS Type III or IV asphalt can be used for base, interply, cap sheet and membrane flashing mopping on slopes $\frac{3}{4}$ " per foot (6.2 cm per meter) and under. Type IV must be used on all slopes greater than $\frac{3}{4}$ " per foot (6.2 cm per meter).

Asphalt Grades for SBS Modified Bitumen Membrane/Felts

Steep or Special Steep grade (Type III or IV) asphalt or SEBS Type III or IV asphalt can be used for SBS base, SBS interply, SBS cap sheet and SBS membrane flashing mopping on slopes $\frac{1}{2}$ " per foot (4 cm per meter) and under. Type IV must be used on all slopes greater than $\frac{1}{2}$ " per foot (4 cm per meter).

ADHESIVES, CEMENTS, COATINGS & PRIMER

All Weather Roofing Asphalt Primer: A penetrating asphalt primer used for prime coating concrete, metal and existing asphaltic surfaces which are to receive asphalt based materials. Applied using a brush or roller. All Weather Roofing Asphalt Primer is asbestos free. 5 gal pail, nominal weight 38 lbs (17.7 kg).

USP® 640 Plastic Roof Cement: Contractor grade, asbestos free plastic roof cement for repairing leaks, cracks, splits, holes and bonding metal flashings. Applied using a brush or trowel. Exceeds ASTM D4586. Maximum VOC content does not exceed 300 grams/liter. 5 gal pail, nominal weight 47 lbs (19 kg).

USP® 901 Premium Modified Adhesive: Contractor grade SBS modified asphalt adhesive for bonding SBS base, SBS interplay and SBS cap membranes. Applied using a notched squeegee. Exceeds ASTM D3019 Type III. Maximum VOC content does not exceed 300 grams/liter. USP® #901 Premium Modified Adhesive is asbestos free. 5 gal pail, nominal weight 47.5 lbs (21.5 kg).

USP® 954 Premium Modified Flashing Cement: Contractor grade SBS modified cement for bonding SBS flashing membranes. Applied using a trowel. Exceeds ASTM D4586. Maximum VOC content does not exceed 300 grams/liter. USP® #954 Premium Modified Flashing Cement is asbestos free. 5 gal pail, nominal weight 45 lbs (20.4 kg).

Generic Insulation Types

The following insulations are acceptable for use with All Weather roofing systems when manufactured to meet the specifications listed and installed in accordance with the insulation manufacturer's recommendations.

1. Perlite - ASTM C728/FS HH-1-529
2. Cellular Foam Glass - ASTM C552/FS HH-1-551E. Must have an overlay of a minimum $\frac{1}{2}$ " (13 mm) of perlite or wood fiber.
3. Glass Fiber Board - ASTM726/FS HH-1-526
4. Glass Faced Gypsum Board – ASTM D1177. *The glass faced gypsum cannot be installed in hot asphalt.*
5. Gypsum Fiber Roof Board – ASTM D1278. *USG® SecuRock Roof Board.*
6. Wood Fiber Board - ASTM C208/FS LLL-1-535b, Class C. *Structodek® High Density Roofing Fiberboard – Celotex™ Blue Ridge™ Fiberboard.*
7. Polyisocyanurate - ASTM C1289/FS HH-1-972, Class 1 or 2. *USP® ISO, USP® Tapered ISO*
8. Expanded Polystyrene - ASTM C578. Must be a minimum of 1.5 lb (80 kg/m³) density.
9. Perlite/Polyisocyanurate/Perlite Composite - FS HH-1-1972, Gen./FS HH-1-1972, 5
10. Perlite/Polyisocyanurate Composite - FS HH-1-1972, Gen./FS HH-1-1972, 3

11. Perlite/Expanded Polystyrene Composite - ASTM C728/FS HH-1-529; ASTM C578/FS HH-1-524C. The polystyrene must be a minimum of 1.5 lb. (80 kg/m³) density
12. Wood Fiber/Expanded Polystyrene Composite - ASTM C208/FS LLL-1-535b, Class C; ASTM C578/FS HH-1-524C. The polystyrene must be a minimum of 1.5 lb. (80 kg/m³) density.
13. Wood Fiber/Polyisocyanurate Composite - ASTM C208/FS LLL-1-535b, Class C; ASTM C1289/FS HH-1-972, Gen.

INSULATION ADHESIVE

3M® Polyurethane Foam Insulation Adhesive CR-20: A low rise, two-component polyurethane froth adhesive specifically designed to adhere a variety of insulation board stock to various substrates porosity in both new and re-roof applications, including applications that require multiple insulation layers.

CR-20 is dispensed from a proprietary disposable gun and hose assembly from a self-contained, ready to dispense two component polyurethane foam adhesive kit.

Polymeric Isocyanate is Component A and is approximately 40 lbs (18.1 kg). Polyol Amines is Component B and is approximately 35 lbs (15.8 kg). Available in regular grade – for use above 40°F; and winter grade – for use 0°F – 40°F (-18°C – 4.4°C).

Coverage is approximately 18-20 squares per unit depending on the substrate and insulation types.

OMG® OlyBond 500® SpotShot Insulation Adhesive: A fast acting, two-component, low rise polyurethane foam adhesive designed to adhere most insulation types to a wide selection of common roof decks and materials. OlyBond 500 can be used in both new and re-roofing applications, including applications that require multiple insulation layers. OlyBond 500 is dispensed in a semi-liquid bead that spreads to several inches before rising $\frac{3}{4}$ " to 1" (19 mm – 25 mm) above the substrate. Available in regular grade – for use in temperatures above 40°F (4.4°C); and winter grade – for use in temperatures from 0°F – 40°F (-18°C – 4.4°C). Packaged in 1,500 ml cartridge sets, 4/case. Coverage is approximately 4 – 6 squares/case depending on the substrate porosity and insulation types.

FASTENERS

The following fasteners are acceptable for use with All Weather roofing systems when manufactured to meet the specifications listed and installed in accordance with the insulation manufacturer's recommendations.

1. Drill Point Coated Fastener - Coated Drill or Thread Point carbon steel, corrosion resistant fastener meeting the requirements of FM 4450/4470. Driven through a minimum 3" (7.6 cm) plate for use over steel decks.
2. Cap Head Nail – 1" (25 mm) diameter round or square cap, or annular threaded roofing nail with 3/8" (10 mm) diameter head/11 gauge, annular or spiral threaded shaft. For use over non-insulated wood decks.
3. Threaded Roofing Nail - 3/8" (10 mm) diameter head/11 gauge, annular or spiral threaded; must be driven through minimum 1" (25 mm) diameter or square cap plate. For use over non-insulated wood decks.
4. Spiral Fluted Concrete Fastener – driven through a 3" (7.5 cm) plate. For use over concrete decks.
5. Split Shank Fastener – electro-zinc galvanized shank, when driven spreads out to provide backout resistance. Pre-assembled with a compatible 3" (7.5 cm) plate. For use over non-insulated gypsum or lightweight concrete decks.
6. Twin Split Shank Fastener – electro-zinc galvanized dual split shanks, when driven both shanks spread out to provide

backout resistance. Pre-assembled with a compatible oval plate. For use over non-insulated gypsum or lightweight concrete decks.

7. Preassembled Locking Tube Nail – factory assembled tube and disk with a locking stable formed from high tensile steel wire. For use over insulated and non-insulated gypsum or lightweight concrete decks and structural wood fiber decks.
8. Nylon Screw – two-piece reinforced nylon screw and plate system with deep slotted, self-locking design, with 3” (7.5 cm) metal plate. For use over insulated and non-insulated gypsum or structural wood fiber decks.

SURFACINGS & WALKWAYS

All Weather Roofing Granules are made from 3M™ Classic Roofing Granules and are designed to match the granule surfacing of All Weather Roofing membranes. All Weather Roofing Granules are a unique, natural mineral product, the only type of roofing granule that meets the toughest test of time, weather and the marketplace.

The granules are dense and non-porous, resist ultra-violet light and are tough enough to stand up under handling. And they hold the long-lasting ceramic coatings added to create the ever-growing selection of colors demanded by the roofing market.

All Weather Roofing Granules are available in 45 lbs (20.4 kg) pail and 25 lbs (11.3 kg) bag. Colors are White, Black, Cedar Blend, Dark Brown, Gray, Tan, and Weathered Wood. Custom colors are available upon request.

All Weather Roofing WalkPad is a composite adhered modified bitumen sheet consisting of a smooth underside and a granule top side. Each layer is manufactured with a heavyweight polyester mat designed and constructed to be strong, while remaining wrinkle resistant. The All Weather Roofing WalkPad is available in APP modified bitumen polymer or SBS polymer and asphaltic bitumen for a strong, durable sheet. Designed for use as a designated walkway for built-up and modified bitumen roofs.

All Weather Roofing WalkPad-APP are designed to be torch applied. All Weather Roofing WalkPad-SBS may be mopped or adhered with SBS adhesive. WalkPad size is 32” x 32”.

GENERAL INFORMATION

INTRODUCTION

This manual is designed to assist and inform the design professional, contractor or owner by providing general and specific recommendations when installing All Weather Roofing membranes and related components that complete the roof system.

These recommendations have been prepared, and are offered as a guide, to assist architects, roof consultants, engineers, roofing contractors, and/or building owners who are responsible for the design of the low slope roof systems. The roofing contractor is solely responsible for the quality of the application of the roof system.

DESIGN AND CONSTRUCTION

All Weather Roofing Products as a materials supplier is not involved in the design or construction of buildings and structures. All Weather will under no circumstances accept responsibility for the performance of its products when damage to its products result from things such as improper building design, construction faults, or defects in workmanship. All Weather Roofing does not manufacture roof decks and is not responsible for their performance.

All Weather Roofing will not write any letters regarding the installation or application of a roofing system that is not to be covered by an All Weather Warranty, nor will it write a letter regarding information that is published in this Application and Specification Manual or other All Weather product literature.

Unless otherwise informed in writing by the All Weather Technical Services Manager, only the materials and procedures referenced in this manual are to be employed in the application of All Weather Roof Systems, including flashing details. The use or misuse of any materials and methods not approved by All Weather is in no way the responsibility of the Company.

When no warranty is purchased, All Weather will not write or sign letters:

- (a) Stating its representatives have examined plans, details or specifications which are acceptable to receive All Weather roofing materials, or
- (b) Stating that a roof has been applied according to All Weather specifications or recommendations for a warrantable roof system, or
- (c) Orally issue any warranty or product warranty other than the published product warranty, or published roof system warranty, or Inspect or comment on the application of the roof.

SPECIFICATIONS

We recommend that design professionals supplement their specifications of the All Weather Roofing systems described in this manual only with specifications outlined in the most recent National Roofing Contractors Association publication. Deviation from known and accepted specifications may lead to problems with the roof system.

General and installation recommendations as stated in this Manual shall be considered a part of the specifications and details presented in the publication.

Project specifications calling for upgrading All Weather specifications must be approved in writing by All Weather Roofing Technical Manager.

All Weather Roofing Products assumes no liability with respect to any supplemental advice, variation from the recommended methods of application or specifications, or any particular roof or roof application unless expressly set forth in writing and signed by the All Weather Roofing Technical Manager.

All Weather Roofing Products reserves the right to change or modify, at its discretion, and without prior notice, any of the information, requirements, specifications or policies contained herein.

SERVICE

All Weather Roofing Products believes in giving the roofing professional what they *want* and *need* out of a quality product. For technical assistance please call us at 817-413-0103.

All Weather Roofing can provide recommendations to architects, engineers and roofing contractors for specifying, detailing, and installing All Weather modified bitumen roofing systems.

HANDLING AND STORAGE

All Weather roofing materials leave the factory dry and in good condition.

Every effort must be made to ensure the materials are stored to prevent the materials from getting wet.

Unload and handle all roofing and construction materials with care.

Examine all materials as they are received. Do not use any materials that are damaged, unlabeled or otherwise appear to be unfit for use. Materials must display legible labels, which identify the materials and applicable reference standards. Immediately notify carrier and All Weather or other manufacturer of damaged, wet, or defective materials. All Weather will not accept responsibility for damage to its products due to circumstances and events beyond our control; including damage in transit, storage at distribution or warehouses or on jobsites.

Do not expose materials to moisture in any form before, during, or after delivery to the site. Reject delivery of materials that show evidence of contact with moisture.

At the job site, no more material should be stored than will be used within two weeks. For periods longer than two weeks, the materials should be properly warehoused, i.e., dry, ventilated, on pallets, etc. No more material should be stored on the roof than can be used within five days. When prolonged inclement weather threatens, i.e., rainy seasons, no more roofing materials should be supplied to the rooftop than can be used within two days.

Store roll goods on end with selvage edge up on pallets in a clean, dry, well ventilated protected area. Take care to prevent damage to roll ends or edges. Rolls stored on their sides will flatten and stick together, rolls stored with selvage edge down will crush the edge making them very difficult to apply and seal the edges.

Do not double stack modified bitumen products.

Remove manufacturer supplied plastic covers from materials provided with such covers. Use "breathable" type covers such as canvas tarpaulins to allow venting and protection from weather and moisture. Cover and protect materials at the end of each day work. Do not remove any protective tarpaulins until immediately before material will be installed.

For best results, store all materials in a shaded area at the job site, even if provisions for covering and ventilation have been performed. When no shaded areas exist for storage, it is recommended to place a layer of minimum 1" thick polyisocyanurate insulation over the top of the rolls

under the tarpaulins to reduce the heat on the rolls and in order to reduce the possibility of rolls sticking.

Should any roofing material become wet or damaged, these materials must not be used; they must be replaced.

During cold weather, store membrane rolls, adhesives and coatings in an area heated at a minimum temperature of 55°F (12.6°C) when the ambient temperature and wind chill factor is below 45°F (7.2°C). This will also help reduce the potential of membrane cracking during handling and installation. Install membrane rolls immediately after removal from storage to avoid membrane cooling to below 45°F (7.2°C).

Materials should be stored above 55°F (12.8°C), a minimum of 24 hours prior to application.

It is recommended that rolls be applied only when the ambient temperatures are above 45°F (7.2°C) for all APP modified bitumen products and 32°F (0°C) for all SBS modified bitumen products.

If temperature at night is at or below 45°F (7.2°C); do not start installation first thing in the morning. The surface over which the membrane is to be installed must be allowed to warm to a temperature above 55°F (12.6°C). Membrane application to cold substrates may result in an improper bonding.

During installation, if surface cracking appears in the membrane, discontinue installation immediately and contact All Weather Roofing Technical Services, 817-413-0103.

Do not apply All Weather roofing materials when the ambient temperature and wind chill factor is below 45°F (7.2°C) unless the following recommendations for application during cold weather are followed:

1. Do not throw rolls of membrane on the deck or storage surface. Sudden impact of the roll can cause cracking of the modified bitumen compound.
2. Roofing materials cannot be applied unless correct asphalt application temperatures can be maintained. Roof membrane application shall not be continued during cold weather unless asphalt temperatures at the point of application can be consistently maintained at the asphalt EVT, or 425°F (218°C), whichever is greater for SBS membranes.
3. Mopped asphalt tends to congeal rapidly and lose its adhesive characteristics in cold weather, so extra care must be taken to set insulation or roofing quickly. Use the minimum insulation board size available.
4. The use of an insulated, two-pipe circulating pumping system for asphalt is recommended for minimizing excessive application of asphalt in cold weather and for reducing use of heating fuel.
5. Do not overheat the bitumen above the Flash Point or above the Finished Blowing Temperature for prolonged periods, to try to offset rapid chilling.
6. Keep the insulation or roofing roll close behind the mop. Mop no farther than 5' (in front of the roll and broom all glass felts immediately after embedment.
7. Brooming glass felts is critical during cold weather and is mandatory for roofing applications warranted by All Weather.
8. When water in any form is present on the deck, application procedures must be suspended until the deck has dried. Any moisture present at the time the roofing is applied may result in poor adhesion and blistering of the membrane.

9. Discontinue work if proper bitumen application temperatures cannot be consistently maintained or materials cannot be securely attached to their substrate.
10. Do not overheat APP membranes to compensate for cold temperatures. Unroll the membrane slowly to ensure proper flow of the compound. Also adjust amount of heat coming from propane torch accordingly.
11. Do not install cold adhesive in temperatures below 45°F (7.2°C).
12. Do not install coatings in temperatures below 55°F (12.6°C).

In the unlikely event that obviously defective or damaged material reaches the job site or damage to the material occurs from improper storage on the job site, it is the responsibility of the roofing contractor not to install this material. All Weather Roofing Products should be notified immediately about material that has apparent manufacturing defects. Installation of defective material can result in additional costs above the cost of supplying replacement material. If the roofing contractor chooses to install material with apparent defects, this added cost is not the responsibility of All Weather.

BUILDING CODE

The architect, contractor, engineer and/or specifier should be familiar with the most current local building and energy codes and design guide requirements affecting the project where installation is to occur. Contractor should obtain any permits necessary before work commences.

Many new code requirements are in effect which are reflected in the most current International Building Code (IBC) or Uniform Building Code (UBC). Such changes include thermal insulation requirements, wind uplift requirements, and changes to ANSI/SPRI ES-1 regarding roof perimeter edges, parapets, wall construction and flashings. Applicable code versions in effect vary from state to state and city to city.

FIRE RESISTANCE

The following are common fire codes and approvals typically used in conjunction with roofing systems:

1. Primary testing is based on ANSI/UL 790, which is similar to and meets all criteria of ASTM E-108. Tests for all decks measure flame spread on exterior surface of roof assembly.
2. Additional testing for combustible decks is also based on ANSI/UL 790. This measures burn-through resistance from exterior through roof system-roof deck assembly.
3. Ratings provided in Underwriters Laboratories Roofing Materials and Systems Directory as "Class A", "Class B", and "Class C" assemblies. Class A is the superior rating.
4. Roof deck-roof system assemblies must be constructed in exact accordance with the components listed for each rated assembly. No material substitutions are allowed.
5. UL ratings are required by building codes for most building applications.
6. Testing based on ANSI/UL 253, which is similar to ASTM E-119. This measures burn-through resistance from interior through exterior of ceiling-roof deck-roof system assembly.
7. Ratings provided in Underwriters Laboratories Fire Resistance Directory as "P-Number" assemblies.
8. Ceiling-roof deck-roof system assemblies must be constructed in exact accordance with the components listed for each P-Number assembly. No material substitutions are allowed.
9. Hourly ratings are required by building codes for special building applications, and are usually not specified if not specifically required by code.

10. Testing based on ASTM E-108. Measures flame spread on exterior surface of roof assembly.
11. Ratings provided in Factory Mutual Approval guide, typically as part of a comprehensive roof system approval that also includes wind and hail resistance as other major test criteria.
12. Roof deck-roof system assemblies must be constructed in exact accordance with the components listed for each rated assembly. No material substitutions are allowed. ASTM E-108 Class ratings are required by building codes for most building applications, and are provided as part of an overall roof system approval. Current All Weather listings are found in UL File directory R11662 in the appropriate UL directory to verify roof assembly requirements for specific fire ratings.

WIND RESISTANCE

Resistance by the roofing system to wind forces is an obvious requirement. Ideally, roofing systems should be capable of resisting the forces generated by the maximum anticipated wind speed for a specific building. It is widely accepted method for specifying wind performance is to require a system rating meeting or exceeding the design pressures calculated in accordance with ASCE-7 or Factory Mutual.

In general, additional securement of the roofing insulation and/or membrane can accommodate most requirements. However, each building is unique and certain conditions and factors may require additional design and implementation to meet the necessary uplift design. This responsibility should typically be undertaken by the project architect, design engineer or roofing consultant.

ROOF DECKS

All Weather Roofing Products does not design or manufacture structural roof decks and is not responsible for their selection, design, and/or performance. The responsibility for roof deck system design, including roofing system selection, vapor retarder, thermal insulation, slope and drainage layout and expansion joints, lies with the architect, roof consultant, engineer, owner or contractor and not with the roofing materials manufacturer.

Acceptance of the deck for application of the roof system is the responsibility of the architect and/or designer.

The minimum roof deck construction and deck surface preparation recommendations which follow are provided as a supplementary guide for the roof deck designer and erector.

New or unusual decks and substrates or any deck type not included in this manual must be approved in writing by All Weather Technical Services to achieve a specification eligible to receive an All Weather Warranty.

Decks must be adequately smooth and level to provide support and maximum contact surface for roofing materials. The surface of the roof deck must be dry (free of moisture in any form), firm, smooth, clean, free of debris, sharp projections and depressions.

Remove electrical conduits, bolts, and other small items from the surface of the roof deck as these areas cannot be properly insulated and roofed.

All depressions, holes, deformations, etc. shall be made smooth prior to the roofing application.

All decks must be properly designed and constructed in accordance with the deck manufacturer's requirements and specifications, must be installed by applicators approved by deck manufacturer, must be able to support and secure the All Weather Roof System, and must be properly related to the rest of the building.

None of the foregoing factors is the responsibility of All Weather Roofing Products which under no circumstances will assume any such responsibility.

Complete all openings or projections (all pipes, vents, ducts, stacks and openings, etc.) through the deck prior to roof system installation. No projections shall be constructed through the flashing cant and projections shall be located a minimum 18" (46 cm) from the intersection of the cant and roof deck.

Do not install electrical conduit or piping immediately above the roof deck. Roof systems cannot be properly installed and adhered around and/or over conduit.

All roof decks shall be designed and constructed:

1. To support maximum loads which may be imposed during and after construction without excessive deflection (1/240 of the span at mid span is the rule for maximum allowable deflection);
2. To provide a minimum ¼" (6 mm) per-foot slope and/or designed so that ponding water dissipates within a 48 hour period.
3. Decks should be designed and constructed to resist wind uplift forces anticipated in the area, and provide satisfactory base to which the roofing can be attached.
4. Interior drains should be sumped below roof level to allow immediate water runoff.
5. Provisions to prevent asphalt drippings must be given consideration where joints, cracks, or holes occur.
6. On slopes ¾" per foot (6 cm per meter) or greater, provisions must be made for insulation stops and/or back nailing of builtup felts or SBS membranes. Insulation stops and/or backing nailing must be used on slopes greater than 1" (8 cm per meter) when adhered single ply membranes are used;
7. Use with suitable expansion joints to accommodate structural expansion and contraction. Expansion joints must extend through the structural system to be acceptable, and must separate adjoining units, or additions. (See also Expansion Joints, this section).
8. Deck materials must be fastened to supporting members by clips, welding or other mechanical devices to prevent lateral and vertical movement of the elements;
9. To be consistent with applicable trade associations, as well as any code or insurance requirements. The roof decks mentioned in this section are those most widely used in the United States. Many decks are used on a regional basis or are not commonly used. Contact All Weather Roofing at 817-413-0103, for deck types or conditions not addressed in this Manual.

Steel Decks

Steel decks should be a minimum 22 gauge (0.8 mm), of configurations specified by the current Steel Deck Institute Manual, and comply with the gauge and span requirements as set forth by the deck manufacturer, and installed in accordance with all other industry standards and current Factory Mutual Loss Prevention Data Sheet 1-28.

Steel deck sections must be securely fastened or welded as applicable in accordance with deck manufacturer's requirements to meet specified wind load criteria. All fasteners and welds should be checked before installation of roofing system to ensure functional ability.

Wood nailers of equivalent thickness to the roof insulation must be provided at perimeters and projection openings to act as an insulation stop and to provide nail holding capability for the nailing flanges of metal flashing.

Rigid roof insulation boards and when applicable the base sheet must be uniformly secured to the steel deck with approved mechanical fasteners. Contact All Weather Roofing 817-413-0103 for approval of any other method.

When mechanically attaching insulation, steel decks should have a minimum fastener pullout strength of 300 lb (1.8 kN) per fastener. Higher fastener withdrawal resistance values and denser patterns may be necessary to achieve higher uplift ratings. Decks which cannot provide the minimum withdrawal resistance are not suitable to receive a roof system.

Poured Structural Concrete

The deck should be smooth, level and free from moisture or frost. All sharp ridges or irregularities should be leveled prior to application of roofing materials.

Fill depression with cement grout or other deck manufacturer approved material. Treat cracks greater than 1/8" (3 mm) in accordance with the deck manufacturer's recommendations.

Newly poured decks should be properly cured prior to application of the roofing system. Twenty-eight (28) days is normally required by deck manufacturer for proper curing. Curing agents shall be checked for compatibility with roofing materials.

Concrete deck surfaces should be primed with asphalt primer, ASTM D 41, at a rate of 1 gal/square (0.4 L/m²) to assure proper adhesion of the roofing membrane or roof insulation. Asphalt primer should be allowed to **completely** dry before beginning installation of the roof system.

Sumps should be provided in the casting of the deck at the location of roof drains. When insulation is used, the thickness of roof insulation should be reduced in a tapered profile around the roof drains to provide positive drainage.

Decks with broomed or textured finishes **are not acceptable** if a membrane system is to be applied directly to the roof deck.

Wood nailers should be installed into the deck to provide for securement of the roofing membrane flashings at perimeters, penetrations and other deck openings.

One way moisture relief vents are recommended over this type of deck.

When mechanically attaching insulation, structural concrete roof decks should have a minimum fastener pullout of 300 lb (1.8 kN) per fastener. Higher fastener withdrawal resistance values and denser patterns may be necessary to achieve higher uplift ratings. Decks which cannot provide the minimum withdrawal resistance are not suitable to receive a roof system.

Precast Concrete

The deck should be smooth, level and free from moisture or frost. All sharp ridges or irregularities should be leveled prior to application of roofing materials.

All necessary precautions should be taken to avoid entrapment of moisture under the roofing system. If the deck is wet, then the deck must be allowed to dry.

Do not seal joints between slabs; leave open to permit venting and drying of roof fill from below. If joints are sealed make other provisions for venting.

All severely deformed panels should be replaced. Fill depression with cement grout or other deck manufacturer approved material. Treat

cracks greater than 1/8" (3 mm) in accordance with the deck manufacturer's recommendations.

Newly poured decks should be properly cured prior to application of the roofing system. Twenty-eight (28) days is normally required by deck manufacturer for proper curing. Curing agents shall be checked for compatibility with roofing materials.

Precast concrete deck surfaces should be primed with asphalt primer, ASTM D 41, at a rate of 1 gal/square (0.4 L/m²) to assure proper adhesion of the roofing membrane or roof insulation. Asphalt primer should be allowed to **completely** dry before beginning installation of the roof system.

If deck is topped with poured gypsum, see also this Section, for general recommendations relative to the use of poured gypsum.

If deck is topped with lightweight concrete or cellular concrete, see also this Section, for general recommendations relative to the use of lightweight concrete or cellular concrete.

Pre-stressed Concrete

This type of deck should not permit ponding water. Offsets between panels should not exceed 1/8". Variations in camber and thickness of pre-stressed concrete members may make securement of the roof system difficult. Grouting at joints has often proven unsatisfactory in attempting to compensate for uneven deck surfaces. Surfaces which are uneven are deemed unacceptable.

A minimum 2" (5 cm) fill is recommended to be installed over all pre-stressed concrete decks prior to installation of the roof system and/or insulation.

The deck should be smooth, level and free from moisture or frost. All sharp ridges or irregularities should be leveled prior to application of roofing materials.

All necessary precautions should be taken to avoid entrapment of moisture under the roofing system. If the deck is wet, then the deck must be allowed to dry.

Newly poured decks should be properly cured prior to application of the roofing system. Twenty-eight (28) days is normally required by deck manufacturer for proper curing. Curing agents shall be checked for compatibility with roofing materials.

If deck is topped with poured gypsum, see also this Section, for general recommendations relative to the use of poured gypsum.

If deck is topped with lightweight concrete or cellular concrete, see also this Section, for general recommendations relative to the use of lightweight concrete or cellular concrete.

Lightweight and Cellular Concrete

Lightweight insulating concrete decks contain a large percentage of moisture. All necessary precautions must be taken to avoid entrapment of moisture under the roofing system; including but not limited to venting at the bottom and top side of the deck, as well as at the perimeter and all penetrations.

The following minimum guidelines are recommended by All Weather when installing a roof system over Lightweight or Cellular Concrete Decks:

1. Lightweight or cellular concrete decks should be installed in strict accordance with the deck manufacturer's requirements and specifications.
2. Lightweight and cellular concrete decks should have a minimum compressive strength of 125 psi (8.79 kg/m²) and

density of 22 pcf (352 kg/m³). Decks with compressive strengths less than 125 psi are unacceptable.

3. A minimum top surfacing thickness of 2" (5 cm) fill is recommended.
4. During curing or application the lightweight or cellular concrete decks should not be subjected to rain or temperatures that are below 40°F (4.4°C). Lightweight or cellular concrete decks that have been frozen before they are cured are not acceptable to receive a roof system and must be replaced.
5. Drying time for decks vary. Follow the deck manufacturer's recommended drying time.
6. Aggregate based lightweight concrete decks require bottom side venting as provided by slotted galvanized steel decks. Solid steel decking and structural concrete decks are not acceptable to receive an aggregate based lightweight insulating concrete mix.
7. Cellular lightweight insulating concrete decks can be installed over non slotted, galvanized steel decking or structural concrete; it does not require a venting substrate.
8. Lightweight or cellular concrete decks must be smooth, and be free from deflections and ridges. Fill depressions with a material approved by the deck manufacturer.

When mechanically attaching insulation through lightweight insulating concrete, into a structural deck, a fastener withdrawal resistance of 300 lb (1.8 kN) per fastener is required.

Decks should provide a minimum 40 lbs fastener withdrawal resistance for the selected approved mechanical base ply fastener at the time the roof system is installed. This is based on a design value of 60 psf using a pattern of 9/18/18.

Higher fastener withdrawal resistance values and denser patterns may be necessary to achieve uplift ratings greater than 60 psf. Decks which cannot provide the minimum withdrawal resistance is not suitable to receive a roof system.

Deck manufacturer and authorized applicator should provide all parties concerned with a letter of certification stating the deck complies with the deck manufacturer's requirements and specifications.

Roof vents (one for each 10 squares or 92.9m²) must be used. Pressure relief vents must be of a one-way design. If roof insulation is used, vent openings should extend through the entire roof system and insulation to the deck or fill surface.

Individual lightweight and cellular concrete manufacturer's standards apply when their specifications exceed the referenced All Weather minimum compressive strength and density requirements.

Mechanically fasten venting base or inverted cap sheet to newly poured aggregated based lightweight insulating concrete decks prior to installing insulation or roofing membrane. On cellular lightweight concrete decks, a glass base sheet can be used in lieu of a venting base or an inverted cap sheet.

On existing lightweight or cellular concrete decks, insulation or a base sheet may be mechanically attached to the deck provided it is dry.

Do not attach insulation directly to newly poured lightweight or cellular concrete decks. Do not solid mop the base ply of the roofing system to a lightweight or cellular concrete deck.

Poured Gypsum

Poured-in-place insulating gypsum decks contain a large percentage of moisture. All necessary precautions must be taken to avoid entrapment of moisture under the roofing system; including but not limited to

venting at the bottom and top side of the deck, as well as at the perimeter and all penetrations.

The following minimum guidelines are recommended by All Weather when installing a roof system over Poured Gypsum Decks:

1. Gypsum concrete decks must be installed in strict accordance with the deck manufacturer's recommendations and specifications.
2. A minimum top surfacing thickness of 2" (5 cm) fill is recommended.
3. During curing or application the lightweight or cellular concrete decks should not be subjected to rain or temperatures that are below 40°F (4.4°C). Lightweight or cellular concrete decks that have been frozen before they are cured are not acceptable to receive a roof system and must be replaced.
4. Drying time for decks vary. Follow the deck manufacturer's recommended drying time.
5. Gypsum concrete decks must be smooth, and be free from deflections and ridges. Fill depressions with a material approved by the deck manufacturer.
6. When attaching insulation to a gypsum roof deck, a fastener pullout of 300 lb (1.8 kN) per PlyFast® Gyptek Fastener is required.
7. Decks should provide a minimum 40 lbs fastener withdrawal resistance for the selected approved mechanical base ply fastener at the time the roof system is installed. This is based on a design value of 60 psf using a pattern of 9/18/18. Higher fastener withdrawal resistance values and denser patterns may be necessary to achieve uplift ratings greater than 60 psf. Decks which cannot provide the minimum withdrawal resistance are not suitable to receive a roof system.

Deck manufacturer and authorized applicator should provide all parties concerned with a letter of certification stating the deck complies with the deck manufacturer's requirements and specifications.

Roof vents (one for each 10 squares or 92.9m²) must be used. Pressure relief vents must be of a one-way design. If roof insulation is used, vent openings should extend through the entire roof system and insulation to the deck or fill surface.

Mechanically fasten venting base or inverted cap sheet to newly poured gypsum decks prior to installing insulation or roofing membrane.

On existing gypsum decks, insulation or a base sheet may be mechanically attached to the deck provided it is dry.

Do not attach insulation directly to newly poured gypsum decks. Do not apply any roofing system by hot asphalt, cold adhesive or torch welding direct to a poured gypsum deck.

Wood Plank Decks

The following minimum guidelines are recommended by All Weather when installing a roof system over wood decks:

1. Lumber should be a minimum of 4" (10 cm) and a maximum of 8" (20 cm) wide and a minimum of 3/4" (18.7 mm) thick (nominal).
2. Any knotholes or large cracks in excess of 1/4" (6 mm) should be covered with strips of sheet metal nailed firmly in place.
3. Lumber boards must be securely fastened to the joists or trusses and must be firmly supported on at each end.

When mechanically attaching insulation or base sheets, wood decks are required to have a fastener withdrawal resistance of 300 lb (1.8 kN) per fastener.

When nailing a base sheet, wood decks are required to have a fastener withdrawal resistance of 40 lb (0.24 kN) for cap nails per fastener.

Higher fastener withdrawal resistance values and denser patterns may be necessary to achieve higher uplift ratings. Decks which cannot provide the minimum withdrawal resistance are not suitable to receive a roof system.

Plywood Decks

The following minimum guidelines are recommended by All Weather when installing a roof system over Plywood Decks:

1. Each panel of soft plywood shall be identified with APA grade trademarks owned by the American Plywood Association and shall meet the requirements of Product Standard PS-1 for soft plywood construction.
2. All plywood which has any edge or surface permanently exposed to the weather shall be of the exterior type.
3. Install with face grain across supports, except where noted. Suitable edge supports shall be provided where indicated on drawings (or in recommendations of the American Plywood Association) by use of ply clips, tongue and groove panels or lumber blocking between joists.
4. Exterior grade plywood should be used for commercial deck construction.
5. Minimum recommended deck thickness is 15/32" (12 mm), over joists not greater than 24" o.c. (61 cm).
6. Must be installed so that all four sides of each plywood panel bear on and are secured to joists and cross blocking; the plywood must be secured in accordance with the American Plywood Association (APA) recommendations. In the absence of cross-blocking, two-ply clips per 24" max joist spacing, should be used.
7. Wood decks must be kept dry prior to the application of the roofing system. Store on raised skids or platforms, and roofed promptly after installation.
8. Panels must be installed with a 1/8" to 1/4" (3mm - 6mm) gap between panels and must match vertically at joints to within 1/8" (3mm).
9. Knotholes or large cracks in excess of 1/4" (6mm) should be covered with securely nailed sheet metal.

Only wolmanized lumber should be used for blocking. The use of petroleum treated lumber is not acceptable.

When mechanically attaching insulation or base sheets, plywood decks should have a fastener withdrawal resistance of 300 lb (1.8 kN) per fastener.

When nailing a base sheet, wood decks are required to have a fastener withdrawal resistance of 40 lb (0.24 kN) for cap nails per fastener.

Higher fastener withdrawal resistance values and denser patterns may be necessary to achieve higher uplift ratings. Decks which cannot provide the minimum withdrawal resistance are not suitable to receive a roof system.

Preservatives or fire retardants used to treat decking must be compatible with roofing materials.

Buildings should be heated gradually after roof system installation is completed.

Oriented Strand Board (OSB) – Waferboard

The following minimum guidelines are recommended by All Weather when installing a roof system over oriented strand board (OSB) decks:

1. Use only OSB decks with the Structural 1 – APA rating and are a minimum thickness of 7/16" (10.5mm), over joists not greater than 24" o.c. (61 cm).
2. Install with face grain across supports, except where noted. Suitable edge supports shall be provided where indicated on drawings (or in recommendations of the American Plywood Association) by use of ply clips, tongue and groove panels or lumber blocking between joists.
3. Exterior grade plywood should be used for commercial deck construction.
4. Must be installed so that all four sides of each plywood panel bear on and are secured to joists and cross blocking; the plywood must be secured in accordance with the American Plywood Association (APA) recommendations. In the absence of cross-blocking, two-ply clips per 24" max joist spacing, should be used.
5. OSB decks must be kept dry prior to the application of the roofing system. Store on raised skids or platforms, and roofed promptly after installation.
6. Panels must be installed with a 1/8" to 1/4" (3mm - 6mm) gap between panels and must match vertically at joints to within 1/8" (3mm).

When mechanically attaching insulation or base sheets, OSB decks should have a fastener withdrawal resistance of 300 lb (1.8 kN) per fastener.

When nailing a base sheet, wood decks are required to have a fastener withdrawal resistance of 40 lb (0.24 kN) for cap nails per fastener.

Higher fastener withdrawal resistance values and denser patterns may be necessary to achieve higher uplift ratings. Decks which cannot provide the minimum withdrawal resistance are not suitable to receive a roof system.

Structural Wood Fiber Decks

The following minimum guidelines are recommended by All Weather when installing a roof system over Structural Wood Fiber Decks:

1. Use only structural wood fiber decks that have a minimum 2" (51 mm) thickness.
2. Decks must be a minimum design load as recommended by the deck manufacturer.
3. Anchor all slabs against uplift and lateral movement.
4. Joints must be level; deck erector must correct any irregularities with a screed coat material as recommended by deck manufacturer.
5. Decks must be smooth, and be free from deflections and ridges. Fill depressions with a material approved by the deck manufacturer.
6. Remove decking which becomes wet or is deformed and replace with new decking.
7. Cover decking with roofing immediately to avoid potential water damage to deck.

Do not install decks over high humidity occupancies. When mechanically attaching insulation, structural wood fiber decks should have a fastener withdrawal resistance of 300 lb (1.8 kN) for each fastener.

When nailing a base sheet, structural wood fiber decks are required to have a fastener pullout of 40 lb (0.24 kN) for PlyFast® Double Lock Nail per fastener.

Higher fastener withdrawal resistance values and denser patterns may be necessary to achieve higher uplift ratings. Decks which cannot provide the minimum withdrawal resistance are not suitable to receive a roof system.

VAPOR RETARDERS

All Weather does not review or calculate dew point analyses and therefore, does not accept responsibility for damage due to recurrence rate or location of the dew point. Although not all projects require a vapor retarder, a design review should be considered for all projects.

The decision to use or not to use a vapor retarder rests with the designer, architect or engineer after careful consideration of design and environmental criteria, including relative interior humidity, interior temperature, type of construction, building occupancy and exterior cold weather temperature variables.

The inclusion of an air barrier or vapor retarder may affect the Underwriter Laboratory or Factory Mutual rating including the attachment of the All Weather roof system.

A vapor retarder may be necessary when high interior humidity conditions will likely require the use of a vapor retarder except when located in the most southern climates. High interior relative humidity is present in swimming pools, food processing, laundry facilities, paper mills, breweries, foundries and bottling plants. In these cases vapor drive may form a dew point under the roof membrane or in the insulation.

In these types of environments the vapor drive can be substantial and the potential exists for moisture accumulation within the roof assembly if an effective vapor retarder is not included in the roof assembly. This movement is reversed in some air-conditioned buildings in humid summer conditions.

Vapor retarders are installed to prevent several types of roof assembly failures:

1. Wet insulation becomes a conductor of heat rather than an insulator and reduces insulation R-value.
2. Moisture promotes the deterioration of the roof membrane, insulation, structural decks, and associated building components.
3. Moisture promotes delamination of roof components by freeze/thaw cycling, eventually causing blisters and delamination when vapor pressure results from solar heating.

The following is a partial list of situations which can influence the need for a vapor retarder:

1. For projects where there is a significant difference in vapor pressure between building interior and exterior, the volume of water vapor flow is much greater, and control of water vapor transfer into and through a roof system becomes an important consideration. Without adequate control provisions, a vapor retarder, the roof insulation can become saturated with water, with a corresponding reduction in insulation thermal performance. Structural deck damage and/or condensation into the building interior may also occur.
2. Building code requirements.
3. Construction generated moisture, particularly during winter construction.

A vapor retarder's effectiveness generally depends upon the following factors:

1. The vapor retarder's perm (permeance) rating which should be as close to zero as possible.
2. Location of the vapor retarder within the system.
3. The integrity of the vapor retarder's seals at perimeters and penetrations.
4. The integrity of the vapor retarder's membrane after other tradesmen finish their projects.

Construction roof traffic should be restricted to prevent damage to the vapor retarder. In the event damage does occur, repair the vapor retarder damage with the same roof components and quantities as specified for the vapor retarder installation.

There are four generally accepted agencies that may help in determining the need for a vapor retarder. They are:

- National Roofing Contractors Association (NRCA) guidelines
- U. S. Army Corp of Engineering Cold Regions Research and Engineering Laboratory (CRREL) guidelines
- American Society of Heating, Refrigerating and Air-Conditioning Engineers (ASHRAE)
- Oak Ridge National Laboratory (ORNL)

These generalizations are not intended to substitute for actual vapor flow calculations based upon specific building and climatic conditions.

In determining the need for a vapor retarder for most typical conditions, the exterior winter temperature and the interior winter relative humidity are the most critical factors.

Temperature information is readily available from the National Weather Service.

Relative humidity information is typically available from the building HVAC design professional or the building operations manager. Relative humidity can also be field measured.

Vapor retarders are intended to be installed as close to the warm side of the roof assembly as possible. Normally, this places the vapor retarder directly on the structural deck or directly over a minimal layer of insulation. **Note: the vapor retarder is not considered a part of the All Weather roofing system.**

The Case for the Use of a Vapor Retarder:

1. A vapor retarder can protect the long term thermal resistance of insulation sandwiched between the vapor retarder and the membrane.
2. A vapor retarder provides a good safeguard against vapor migration in case a building's use changes from a "dry" use to a "wet" use.

The Case Against the Use of a Vapor Retarder:

1. The vapor retarder, together with the roofing membrane, may seal within the roof sandwich entrapped moisture that can eventually destroy the insulation, help split or wrinkle the membrane or, in gaseous form, blister it.
2. In the event of a roof leak through the membrane, the vapor retarder will trap the water in the insulation and release it through punctures, breaks, or poor seals in the vapor retarder that may be some lateral distance from the roof leak, thus making leak discovery more difficult. A large area of insulation may be saturated before the punctured roof membrane can be repaired.
3. A vapor retarder is a disadvantage in summer, when vapor migration is generally downward through the roof (hot, humid air can infiltrate the roofing sandwich through the vents, or through diffusion through the roof membrane; it may condense on the vapor retarder itself).
4. A vapor retarder may be the weakest horizontal shear plane in the roofing sandwich. Failure at the vapor retarder/insulation interface can result in splitting of the membrane. At the least, the vapor retarder introduces an additional component whose shear resistance may be critical to the membrane's integrity

5. Air leakage into the roof system at perimeter and penetrations will significantly reduce the effectiveness of the vapor retarder by allowing moist air to penetrate into the roof assembly where it can condense and cause roof deterioration.

A sufficient amount of insulation must be installed over the vapor retarder so as to raise the dew point location above the level of the vapor retarder.

Vapor retarders shall be completely sealed at all perimeter and penetration locations.

Sealing methods shall be selected in accordance with type of vapor retarder being installed.

RECOVERING EXISTING ROOFS

The term “recover”, as referenced in this Installation Guide, is meant as the installation of a new roof system over an existing roof system. The term “reroof”, as referenced in this Guide, is meant as the removal of the existing roof, prior to the installation of a new roof system. Every roofing project has its own unique problems that require assessment on an individual basis. All Weather Roofing requires that a thorough investigation of the existing roof system and its support system must be made to determine the cause of roof system failure or deterioration. The determination of whether to tear-off or recover an existing roof system is the responsibility of the architect, engineer or owner. All Weather Roofing is not responsible for damage of its roof systems in any way caused by recovering an existing roof system. Due to the complexity of recover and reroofing specification and varying field conditions, contact All Weather Roofing Products, 817-413-0103 for requirements when an All Weather Warranty is required. A recover should be considered only if the following items are addressed and preparation includes:

1. Establishing the history of the old roof system and determining and correcting the cause of any premature roof failures.
2. The existing roof system must be compatible with the proposed new roof assembly. Sprayed in place urethane foam roof systems are not eligible for recover.
3. Determining that the deck is structurally sound to receive a new roof system.
4. Taking test cuts to verify the existing roof construction and condition. Three test cuts should be made for roofs under 100 squares and one test cut per 100 squares above the minimum amount.
5. It is highly recommended that a moisture survey be made to determine the extent of wet insulation and moisture entrapment.
6. All irregularities in the existing membrane and deck system can and are repaired in order to make the membrane ready to receive the new roofing system.
7. Providing for proper drainage of the new roof system to eliminate ponding. Provisions must be made to insure the new roof system has proper drainage, i.e., placement of additional roof drains, use of tapered insulation, use of crickets, etc., as appropriate.
8. The existing membrane surface is in basically sound condition, without excessive quantities of defects such as blisters, ridges, fishmouths, or other irregularities.
9. The existing roof system components are well attached to each other and their substrate.
10. For recover installations, all damaged and/or wet insulation areas must be identified. The affected insulation must be cut out and removed. The removed insulation must be replaced with new insulation of the proper size to fill the space flush

with existing surface and obtain a relatively smooth surface to accept the installation of the new roof system.

11. If the old roof is a coal tar BUR, a divorcing layer of roof insulation must be used.
12. The existing detail conditions are readily adaptable to the increased thicknesses imposed by the recover system and comply with All Weather Roofing specifications and requirements.
13. The new membrane and any new insulation will cause changes in edge details and the height of perimeter nailers.
14. The existing structure is capable of supporting the new loads imposed by the recover system.
15. All applicable code requirements must be met for recover over an existing roofing system.

For recovering over single-ply roof membranes, the existing membrane must be cut into sections no larger than 20' x 20' per each section. All flashing must be removed at the perimeter edge, parapet walls, roof drains and roof penetrations and a cover board must be installed to provide a suitable recover substrate.

For recover over gravel surfaced built-up roofing, the loose gravel must be removed. The surface must be leveled to prevent the insulation or recover board from bridging.

For recover over metal panel roof, contact All Weather Roofing Technical Services for prior approval and technical requirements.

For tear-off project, all existing roofing and flashings must be removed to provide a sound substrate for the installation of a new roofing system and correct existing design deficiencies.

Roof systems having existing vapor retarders must be addressed with our Technical Services at: 817-413-0103.

All Weather Roofing Products does not recommend partial recover or reroofing of a single roof area due to the potential for defects in the portion of the roof system not replaced, to damage or negatively affects the performance of the new membrane. When required by project conditions or budget considerations, All Weather Roofing Products requires full separation of the old and new roof areas by means of a full curb mounted expansion joint or area divider installed to provide a complete watertight seal or break between areas. Tie-in constructions in which the old and new membranes are adhered directly to each other and stripped in are not acceptable for use in All Weather roof systems.

WARRANTY INFORMATION

All Weather Roofing offers several types of warranties. All warranties are “limited” unless they are termed or titled “unlimited warranty”. Any one limitation makes a warranty “limited” in one respect or another.

All Weather Roofing Products Limited Material Warranty

Limited Material Warranties cover the repair of All Weather roof membranes that cause leaks as a result of manufacturing defects in material for the duration of the warranty period, from the date of purchase, subject to the exclusions and exceptions described in the limited material warranty.

On non-warranted roofs, All Weather Roofing acts only as the seller of materials and has no control of the application of materials or the conditions under which they are applied. Under these conditions, All Weather Roofing is not responsible for the performance of the roof beyond the obligation to manufacture and ship quality materials which comply with All Weather Roofing published specification standards.

On non-warranted roofs, All Weather Roofing will accept no responsibility for claims regarding defective materials except as

described below. Every claim for defective materials must be made in writing and received by All Weather Roofing Products, ATTN: Technical Services Department, P.O. Box 163980 Fort Worth, Texas 76161 within thirty (30) days of the date that the claimed defect is or should have been discovered.

Because all factors creating abnormal wind conditions on a roof cannot be entirely anticipated by a roofing manufacturer, All Weather Roofing is not liable in any event for wind damage.

All Weather Roofing Products warrants that, at the time of delivery, the All Weather Roofing Material delivered shall conform to seller's specifications therefor free and clear of all liens and encumbrances. THIS WARRANTY IS EXCLUSIVE AND IS IN LIEU OF ALL OTHER WARRANTIES EXPRESS OR IMPLIED, INCLUDING THE IMPLIED WARRANTY OF MERCHANTABILITY OR FITNESS FOR A PARTICULAR PURPOSE, and of any other obligations or liability on the part of ALL WEATHER ROOFING PRODUCTS whether any claim against it is based upon STRICT LIABILITY, NEGLIGENCE, BREACH OF WARRANTY OR ANY OTHER THEORY OR CAUSE OF ACTION. In no event shall All Weather Roofing Products be liable for CONSEQUENTIAL OR INCIDENTAL DAMAGES of any kind, including but not limited to interior damage. Recommendations made by All Weather Roofing Products are believed to be reliable, but All Weather Roofing Products makes no warranty of results to be obtained. If any of the All Weather Roofing material fails to conform to the foregoing warranty, SELLER'S SOLE AND EXCLUSIVE REMEDY shall be the replacement of such non-conforming material, provided that such material has been handled and installed in accordance with seller's published handling procedures and installation specifications. This warranty does not apply to, and seller shall not be liable for, labor costs or any other damages resulting from improper or faulty installation of material. The Seller shall also not be liable for labor costs or any other damages resulting from failure of the material itself. Regardless of the theory on which a claim may be made including, without limitation, negligence, contract, breach of warranty, strict liability in tort, misrepresentation, or otherwise, with respect to material delivered or for failure to deliver any material, no claims of any kind whatsoever shall be greater in amount than the purchase price of the material in respect of which damages are claimed. In NO event shall All Weather Roofing Products be liable for INCIDENTAL, CONSEQUENTIAL, SPECIAL, INDIRECT OR PUNITIVE DAMAGES.

Exclusions

All Weather limited warranties, even when issued, do not cover and specifically exclude the following conditions or any damage that may arise from:

- Defects in or damage from workmanship in applying membrane, base flashings or any other component.
- Natural forces, disasters, or acts of God including, but not limited to windstorms, fires, hail, hurricanes, floods, tornadoes, windblown debris, lightning, earthquakes, volcanic activity, atomic radiation, insects or animals.
- Damage resulting from any materials used in conjunction with the All Weather Materials, including but not limited to "Radiant Barriers".
- Damage to the products caused by inadequate attic/roof sheathing ventilation (Note: Ventilation must meet the FHA and HUD Minimum Property Standards or a minimum of one (1) square foot of net free attic vent area for every 150 feet of attic floor area; or one square foot per every 300 square feet, if vapor barrier is installed on the warm side of the ceiling, or at least one half the ventilation area is provided near the ridge.

- Damage to the materials caused by any deliberate or negligent act in maintaining the roof or abuse or abnormal use of the roof.
- Failure by the Owner to use reasonable care in maintaining the System, said maintenance to include, but not limited to those items listed on the reverse side of this Limited Warranty titled "All Weather Roofing System Maintenance and Care Program".
- Replacement of products after the first six (6) months after application due to loss of granules.
- Damage due to settlement, distortion, cracking or failure of building components, including, but not limited to, the roof substrate, walls, mortar, HVAC units, etc; vandalism; improper installation of insulation or defects or failure of any material used in any roof base or insulation; infiltration or condensation of moisture in, through or around the walls, copings, building structure, rooftop penetrations or mechanical units or underlying or surrounding materials; defects in workmanship or design; or other materials including, but not limited to metal work, expansion or control joints, walkways, pitch pockets, flashing materials, and any roof top units and equipment; expansion or contraction of any flashing or metal work; applications of roofing materials not in conformity with All Weather Roofing Products installation guidelines at the time of installation; where underlying materials or structures have failed or ceased to conform to All Weather installation guidelines or specifications; chemical attack on the membrane as a result of exposure to chemicals, including but not limited to, aliphatic or aromatic solvents, chlorinated hydrocarbons, oils, or any other corrosive chemical.
- Changes in usage of the building contrary to applicable structure usages over which this limited warranty coverage is extended.
- Damage resulting from any new installations on or through the roofing membrane or flashing or from traffic of any nature on the roof.
- Any repairs or other applications to the roof membrane or base flashing after the date of completion, unless performed in a manner acceptable to and approved by All Weather Roofing Products in writing in advance.
- Any damage occurring more than thirty (30) days after the discovery of a leak by the Owner or its agent, unless All Weather is notified of such leak within thirty (30) days of the discovery.
- Areas of roof which pond water.

Exceptions

All Weather will not issue a warranty of any type for any roof system or material installed on or over the following structures, without prior express written approval by the All Weather Warranty Department prior to application of the roofing materials:

- Cold storage buildings;
- Storage silos;
- Heated tanks;
- Structures outside of the United States;
- Structures with conduit or piping installed between the roof deck and the roof membrane;
- Structures that omit or have an inadequate number and spacing of expansion joints or curbs. Maximum distance allowed between expansion joints is 150 lineal feet (45.72 m);
- When deck materials change direction, different kinds of deck materials abut each other or the building changes direction without an expansion joint; Membrane installations

over thermal insulations or cover boards not approved by All Weather;

- Roofs without positive drainage;
- Structures where high humidity conditions exist such as, but not limited to, breweries, car washes, canneries, creameries, foundries, food processing, laundries, textile mills, pulp and paper plants, swimming pools, shower rooms, and where similar situations exist;
- Membrane installations over thermal insulations not approved by All Weather;
- Roofing over any substrate not specifically addressed in this manual;
- Lightweight insulation concrete unless venting is provided in accordance with All Weather specifications;
- Reroofing over any existing roofing system containing asbestos or sprayed in place urethane foam;
- Reroofing over any existing roofing system containing moisture and/or improperly prepared surface;
- Any surface which is not readily accessible for inspection;
- Plywood decks or OSB decks less than ½” (13 mm) thickness without continuous solid end blocking;
- Waterproofing applications or any below grade application;

Inspections

Inspections are not required by All Weather Roofing Products as a condition for the issuance of the All Weather Limited Material Warranty or the All Weather Limited System Warranty; however, All Weather Roofing reserves the right to inspect any roof where a warranty has been requested or issued.

Any inspections made by All Weather Roofing is for its own use only and does not constitute a waiver of any of the terms and conditions of the warranty.

Should an All Weather Roofing representative observe conditions on the job site which do not conform to the requirements of this specification manual for issuance of the All Weather warranty, such conditions will be brought to the attention of the Roofing Contractor and the Owner’s Representative for corrective action.

APPLICATION INFORMATION

Insulation Application

General: The function of roof insulation is to provide resistance to thermal energy. Benefits can include increased comfort, smaller heating/cooling equipment requirements, lower operating expenses and a reduced consumption of expensive fuel supplies.

All Weather does not consider any roof insulation as being a part of the membrane system and will not warrant the same.

The selection of insulation type, thickness and configuration is the responsibility of the architect, engineer, roofing contractor or owner.

All Weather Roofing reserves the right to accept or reject any roof insulation as an acceptable substrate for the attachment of All Weather roof membranes.

Performance of any manufacturer’s insulation is not warranted by All Weather Roofing, nor will All Weather Roofing accept responsibility for failures or damages to the roof system or membrane caused by the specific insulation used.

The attachment of insulation over the substrate to which it is installed is essential. Insulation shall be attached according to the requirements of the insulation manufacturer, local codes and insurance underwriting agencies.

It is recommended to consult the Factory Mutual Loss Prevention Data Sheet 1-29 for information on insulation attachment requirements.

Do not install insulation in hot asphalt directly to a steel deck. The first layer of insulation must be mechanically attached to a steel deck.

Install insulation to wood or wood fiber nailable decks by either mechanically fastening the insulation or by nailing a base ply to the deck following nailing recommendations for base plies and then installing insulation in a solid mopping of asphalt or low rise, two-component insulation adhesive.

On slopes of ½” (4.2 cm per meter) or greater, consult the insulation manufacturer for recommendations regarding the installation of insulation stops.

All Weather Roofing is not responsible for damage to roofing membranes or flashing from movement or wind uplift due to inadequate attachment of the roof insulation. It is the responsibility of the design professional to determine wind uplift design forces and the means of attaching the roof system to resist those forces.

All Weather Roofing recommends double layer application of roof insulation, to reduce membrane stress and thermal loss at insulation joints and prevent thermal bridging between mechanical fasteners and the roof membrane.

The use of plastic stress plates are not recommended for use with torch applied membranes.

Do not apply roof insulation or roofing until all other work trades have completed jobs that require them to traverse the deck on foot or with equipment.

A vapor retarder coated lightly with asphalt may be applied to protect the inside of the structure prior to the insulation and final roofing installation.

Before the application of the insulation, any damage or deterioration to the vapor retarder must be repaired.

Roof insulation must provide a smooth, dry, clean and firmly attached substrate to receive the roof membrane.

Do not install wet, damaged or warped insulation boards.

Wood nailers must be 3-1/2” (8.9 cm) minimum width or 1” (25 mm) wider than metal flange. They shall be of equal thickness as the insulation with a minimum 1” (25 mm) thickness. All nailers must be securely fastened at outside edges and openings through the deck.

Install insulation boards with staggered board joints in one direction (unless taping joint). Install insulation board snugly. Gaps between board joints must not exceed ¼” (6 mm). All gaps in excess of ¼” (6 mm) must be filled with like insulation material. Edges of insulation board shall be mitered and filled at ridges and elsewhere to prevent open joints or irregular surfaces. Avoid breaking or crushing of the insulation at the corners.

Do not kick insulation boards into place. Install insulation boards per insulation board manufacturer’s requirements.

Insulation boards must be mechanically fastened or attached with hot asphalt or low rise, two-component insulation adhesive as appropriate to the deck. Do not attach with cold adhesive, as it is not acceptable unless approved in writing by All Weather Technical Manager.

Cant strips must be installed at the intersection of the roof and all walls, parapets, curbs, or transitions approaching 90°, to be flashed. They shall be approximately 4” (10.2 cm) in horizontal and 4” (10.2 cm) in

vertical dimension. The face of the cant shall have an incline of not more than 45 degrees with the roof.

Roof tape, if required over insulation joints, must be laid evenly, smoothly and embedded in a uniform coating of hot steep asphalt with 4" (10.2 cm) end laps. Care must be taken to assure smooth application of tape, and full embedment of the tape in the asphalt.

A maximum board size of 4' by 4' (1.22 m x 1.22 m) is to be used if the insulation is to be adhered in asphalt or low rise, two-component insulation adhesive.

Note: Polyisocyanurate insulation boards, require a minimum 1/2" overlay (wood fiber, perlite or minimum 1/4" gypsum) board prior to mopping roof cover. Direct mopping application to polyisocyanurate insulation is not permitted.

If tapered roof insulation is to be installed all hip and valley panels must be mitered. Laced valleys are not acceptable.

Do not install any more insulation than will be completely waterproofed each day.

Insulation Attachment to Nailable Substrates

Where insulation is fastened to the roof deck, a minimum 60 psf attachment is recommended. Where design requirements, local code, insurance or other regulatory requirements dictate higher wind resistance values, the fastening pattern must be enhanced as required by the authority having jurisdiction.

Refer to FM RoofNav including for FM Loss Prevention Data Sheets 1-7, 1-28, 1-29 and 1-49 for FM fastening patterns. Refer to the authority having jurisdiction for all other fastening patterns.

Use only fasteners with a minimum 3" (7.6 cm) stress plate when mechanically attaching insulation. Do not attach insulation with nails.

All Weather recommends that field fastener spacing for single layer installation is one (1) fastener per 2 sq. ft. (0.18 m²). For double layer insulation installation the field fastener spacing is one (1) fastener per 2.67 sq. ft. (0.24 m²), and is applicable only if the second layer is mopped or adhered in low-rise, two component insulation adhesive.

For simultaneous attachment of multiple layers of insulation, preliminary fastening of underlying insulation is recommended. Locate four fasteners (one fastener in each corner area) of the insulation board for 4' x 4' (1.22 m x 1.22 m) panels and five fasteners (one fastener in each corner area and one in the center) of the insulation board for 4' x 8' (1.22 m x 2.22 m) panels.

The fastener density should be increased along the perimeters and in the corners in accordance with design or regulatory requirements.

Insulation Attachment to Non-Nailable Substrates

Poured, pre-stressed and precast concrete decks require priming prior to installation of insulation boards.

Prime the deck with asphalt primer (ASTM D 41) applied at the rate of 1 gal/square (0.41 L/m²) minimum or as required by the primer manufacturer. Hold primer application back 4" (10 cm) from concrete panel joints, cracks or roof openings. Allow the primer adequate time to dry.

Use maximum 4' x 4' (1.22 m x 1.22 m) insulation boards when applying insulation in hot asphalt or low-rise foam adhesive.

Install all insulation boards in full and uniform moppings of hot, fluid asphalt applied at the rate of 25 – 30 lb/square (1.2 – 1.5 kg/m²). Install the insulation with the joints staggered in one direction, assuring that

board ends and sides touch all along their length. Press each board firmly into place.

Install additional insulation layers, maximum 4' x 4' (1.22 m x 1.22 m) board size, in full and uniform moppings of hot asphalt applied at the rate of 25 – 30 lb/square (1.2 – 1.5 kg/m²). Press each board firmly into place. Stagger the joints of each additional layer by as much as possible in relation to the insulation joints in the layer(s) below (minimum 6" (15.2 cm) stagger) to eliminate continuous vertical gaps.

Insulation Attachment with Low Rise, Two-Component Adhesive

General: Thoroughly train all personnel in the recommended equipment and hose assembly, safety procedures and equipment use for dispensing low rise, two-component adhesives. Follow recommended equipment storage, re-use of unused material, dispensing equipment and disposal procedures. Never commence operation until personnel are familiar with and understand the dispensing equipment and how to properly apply the adhesive.

Application Temperature: For best results, all surfaces to be bonded must be clean, dry and free from dirt, dust, oil, loose paint, wax or grease, etc. The temperature of the adhesive should be between 70°-95°F (21°-35°C) and the surfaces being bonded should be at 40°F (4°C) or above. Temperatures outside this range may affect bonding range, dispensability and performance of the product.

Adhesive Application: Use appropriate dispenser to apply the low rise foam adhesive to the desired adhesive pattern. The insulation adhesive is applied in rows placed a maximum of 12" o.c. denser row spacing may be required to achieve higher uplift results.

A maximum board size of 4' by 4' (1.22 m x 1.22 m) is to be used if the insulation is to be adhered in low rise, two-component insulation adhesive. A maximum board size of 4' x 8' (1.22 m x 2.44 m) is permitted for gypsum roof boards.

Insulation boards are to be placed immediately. Follow adhesive manufacturer's specific installation instructions for setting, weighting and walking in boards.

The time involved in this process is contingent on the ambient as well as deck surface temperature.

After the adhesive has attained its initial bond strength, the boards can be "walked-in" and will be compressed to the deck or substrate exhibiting minimal slippage or movement. The boards should be exposed to minimum traffic for at least 10-20 minutes (depending on temperature) after they have been "walked-in-place" to avoid breaking the freshly formed bond. Membranes can be applied once the adhesive has achieved sufficient bond strength to the immediate substrate to which it is adhered. It is recommended that the contractor inspect the installed insulation for proper adhesion and re-adhere any boards and/or corners that are not adequately attached.

Boards that will not lay flat due to cupping, warping or crowning or surface irregularities of the substrate, should have weights placed on the boards until the adhesive has achieved adequate adhesion to hold the boards in place. Once adhesive is set, replace any boards which remain cupped or warped.

Coverboard Requirements

All Weather Roofing approves perlite or wood fiberboard insulation, minimum 1/2" (13 mm) thickness, or approved gypsum roof boards, minimum 1/4" (6.5 mm) thickness may be used as a cover board over polyisocyanurate, polystyrene and foam glass roof insulations. Cover boards are required over these insulations prior to mopping base or other hot asphalt applied membranes over the insulation. Gypsum

cover boards are required for torch applications. Stagger and offset all joints of each insulation layer from underlying layers.

Base Sheet Application

Base sheets should be cut into lengths short enough to be easily handled and allowed to warm and relax prior to installation. Appropriate maximum membrane length will vary depending upon temperature conditions. The base sheet must be warmed to a temperature sufficient to allow expansion and relaxation of the asphaltic coating, prior to application, otherwise wrinkles may form. The applicator must evaluate weather conditions to determine maximum functional length and relaxation time to avoid wrinkling. Place tension on the end of the base sheet during installation to ensure that the sheet lays flat.

Mechanical Attachment: On decks of wood, plywood, OSB, lightweight concrete, gypsum or structural wood fiber without insulation, the minimum base sheet pattern required for the field of the roof shall be as follows: Lap the base sheet 2" (5.1 cm), and mechanically fasten with three rows of fasteners. The first row (on the seam) will be 1" (2.5 cm) from the leading edge and on 9" (22.9 cm) centers. Locate the second row of fasteners 12" (30 cm) from the leading edge and on 18" (45.7 cm) centers. The third row of fasteners shall be 24" (60 cm) from the leading edge on 18" (45.7 cm) centers. The centers for the second and third rows should be staggered from each other.

The fastener density should be increased along the perimeters and in the corners in accordance with design or regulatory requirements.

Over insulation with the fasteners having a 3" (7.6 cm) plate the minimum base sheet pattern required for the field of the roof shall be as follows: Lap the base sheet 2" (5.1 cm). Screws and plates are then installed in three rows. The first row (on the seam) will be 1-1/2" (3.6 cm) from the leading edge and on 12" (30 cm) centers. Locate the second row of fasteners 12" (30 cm) from the leading edge and on 18" (45.7 cm) centers. The third row of fasteners shall be 24" (60 cm) from the leading edge on 18" (45.7 cm) centers. The centers for the second and third rows should be staggered from each other.

The fastener density should be increased along the perimeters and in the corners in accordance with design or regulatory requirements.

Note: When fastening base sheets using screws and plates without insulation, the plate must be of a design that allows it to lie flat on the deck.

Where design requirements, local code, insurance or other regulatory requirements dictate higher wind resistance values, the fastening pattern must be enhanced as required by the authority having jurisdiction.

Hot-asphalt Application: Asphalt shall be applied in a uniform layer, without voids, at a rate of 25 lb/square (1.2 kg/m²) ± 20%. Install full width base sheets, lapping 2" (5.1 cm) on the sides and 4" (10.2 cm) on ends. Stagger adjacent end laps a minimum of 18" (45.7 cm) apart.

Foot and machine traffic on freshly applied membranes with asphalt must be kept to a minimum to reduce the possibility of asphalt displacement due to "point applied" pressure. The potential result is the creation of an area where the asphalt quantity may be too light to perform the required waterproofing function.

Workmen must stand on the insulation or deck side of the system and avoid traffic on the freshly laid membrane system for a long enough time to allow the asphalt to set up. Do not allow equipment over, or store materials on the freshly laid membrane. Asphalt dispensing equipment must have balloon tires.

For slopes under 3/4" per foot (6.2 cm per meter), Type III or IV asphalt can be used when installing insulation and non-SBS felts and base sheets. Type IV must be used on all slopes greater than 3/4" per foot (6.2 cm per meter).

For slopes under 1/2" per foot (4 cm per meter), Type III or IV asphalt can be used for SBS base, SBS interply and SBS cap sheet. Type IV must be used on all slopes greater than 1/2" per foot (4 cm per meter).

Cold Adhesive Application: USP® 901 Premium Modified Adhesive may be used as cold process adhesive for approved base sheets over approved insulations to the horizontal or low slope substrates under 2" per foot (16 cm per meter). For slopes greater than 2" per foot (16 cm per meter), USP® #954 Premium Modified Flashing Cement should be used as cold process adhesive for base sheets and SBS membranes.

For slopes less than 1/2" per foot (4 cm per meter), membrane should be applied shingle style, perpendicular to the slope of the roof deck. On all slopes 1/2" per foot (4 cm per meter) and over membrane should be installed in a strapped fashion or parallel to the slope of the roof.

Backnailing of felts and cap sheet is required when the membrane is installed parallel to the slope.

All laps must be parallel or perpendicular to the slope of the roof so that the flow of water is never against the lap.

Coiled rolls should be unrolled, cut into 18' - 24' (5.5 - 7.3 m) lengths, placed upside down and allowed to "relax" prior to installation. Then reroll to apply.

Install full width sheets, lapping a minimum of 2" (5 cm) on the sides and 6" (15.2 cm) on ends. Stagger adjacent end laps a minimum of 18" (45 cm) apart. Where installed over base sheet, stagger sheet side and end laps from underlying plies.

A minimum 3/8" (10 mm) and maximum 1" (2.5 cm) cold adhesive flowout must be obtained at all seam areas when the side laps are not heat welded. Dry laps are not acceptable. Check all seams for full and uniform adhesion.

Starting at the low point or the drains, apply the cold adhesive to the substrate as follows:

1. Pour the adhesive on the substrate and spread, using a serrated edged squeegee, applied at the rate of 1-1/2 gal/square (6 L/m²), or, spray, using equipment that will apply the adhesive at a rate equal to 1-1/2 gal/square (6 L/m²).
2. Apply the adhesive so that the substrate is coated in a pattern slightly larger than the first sheet being applied:
3. End laps and selvage laps of the base sheet being lapped must be coated with adhesive so that a visible bead of adhesive appears. Roll all laps with a weighted roller to ensure proper adhesion.
4. Allow 5 to 15 minutes for solvents to evaporate from the adhesive (i.e. tack time or open time) before embedding any sheets into newly applied adhesive. (Note: this is only a guide. Tack times depend on such variables as ambient temperatures, humidity, wind, and cloud cover.)
5. Be careful to ensure that the base sheet lays flat in the cold adhesive. There must be complete adhesion between the base sheet and the cold adhesive. Brooming in may be necessary under certain conditions to ensure that the cap sheet adheres solidly to the cold adhesive. Apply extra pressure to avoid creating open channels where three or more membranes are lapped.

Installation must not commence during adverse weather or without precautionary measures in temperatures below 45°F (7.1°C).

All Weather APP Membrane Application

The surface over which the membrane is to be installed must be clean, smooth, and dry and prepared in accordance with this specification manual. Do not apply APP membranes directly to a fresh asphalt glaze or flood coat or over base plies with excessive asphalt mopping bleed out at laps.

Do not install APP torch grade membranes over base plies or materials installed with solvent based cold adhesives or mastics.

For slopes 3" per foot (25 cm per meter) and over, APP torch grade membranes must be run vertically, parallel to the roof. For slopes less than 3" per foot (25 cm per meter), install cap sheet perpendicular to the slope.

Never apply APP membranes by any method except welding with a propane torch or other equipment specifically designed for application of APP modified bitumen.

The coiled membrane must be unrolled approximately 10 ft. (3 meters), aligned, then the propane torch flame applied uniformly across the exposed back surface of the membrane and lap areas until the compound reaches the proper application temperature, causing the compound to develop a slight sheen.

Be sure that there is complete burn-off of release films where present on the underside of the rolls, membrane selvage edges or both surfaces as applicable. Avoid overheating which may result in damage to or improper adhesion of the membrane.

Move the flame from side to side in the shape of an "L", applying about 80% of the heat to the membrane and 20% to the substrate or underlying plies including the lap area of the previously installed courses.)

More heat may be necessary on the substrate by applying 60% of the heat to the membrane and 40% to the substrate in colder temperatures. Also, a slower pace may be required to ensure that proper heating is accomplished.

The membrane is then slowly unrolled as heat is applied to ensure proper adhesion. When complete, re-roll the opposite end of the membrane and install in the same manner.

Install full width sheets, lapping 3" (7.6 cm) on the sides and 6" (15.2 cm) on the ends. Stagger adjacent end laps a minimum of 18" (45.7 cm) apart. All side and end laps must be staggered from underlying plies.

A minimum 3/8" (10 mm) asphalt flow-out must be obtained at all seam areas. Do not exceed a maximum 1" (25 mm) compound flow-out. Dry laps are not acceptable.

1. To ensure the proper 3/8" (10mm) flow of bitumen at the seam areas, a weighted roller may be used. Roller application should follow behind the torch no more than 4 ft. (1.2 m) or less than 3 ft. (0.91 m) to ensure that the membrane will be at the proper temperature to produce proper flow-out.
2. Hand rollers or "walking-in the seam" methods are also acceptable.
3. Check all seams for full and uniform adhesion. Un-adhered seams must be lifted with a heated trowel and resealed by lightly torching the seam area. Press or roll seam to achieve a minimum 3/8" (10 mm) compound flow-out of bitumen.

On a mineral surface, do not attempt to move the trowel laterally while applying pressure as the granules may become displaced. Direct pressure or a light patting action is best.

Matching granules may be broadcast into the modified bitumen bleed out at seams while hot to enhance the finished appearance of the membrane. It is not required for issuance of an All Weather Warranty.

All end laps must be staggered a minimum of 18" (45.7 cm) so that no adjacent end laps coincide. If end laps fall in line or are not staggered the proper distance, a full width of APP membrane must be installed over the end laps. End laps, flashing sheets and other seams formed over granule surfaces require pre-heating of the top surface of the underlying granule surface membrane to a point where the granules just begin to sink into, and the modified bitumen compound comes up through the granules to ensure proper seam construction and adhesion.

All laps must be parallel or perpendicular to the slope of the roof so that water is never against the lap.

APP membranes must not be applied during adverse weather or without precautionary measures in temperatures below 45°F (7.1°C). Also refer to Cold Weather Precautions.

All Weather SBS Membrane Application

Mop Application: For slopes less than 1/2" per foot (4 cm per meter), Type III or IV asphalt can be used. Type IV must be used on all slopes 1/2" per foot (4 cm per meter) and over.

Asphalt shall be applied at its EVT temperature or 425°F (218°C), whichever is greater, in a uniform layer, without voids, at a rate of 25 lb/square (1.2 kg/m²) ± 20%.

For slopes less than 1/2" per foot (4 cm per meter), membrane should be applied shingle style, perpendicular to the slope of the roof deck. On all slopes 1/2" per foot (4 cm per meter) and over membrane should be installed in a strapped fashion or parallel to the slope of the roof.

Backnailing of felts and cap sheet is required when the membrane is installed parallel to the slope.

Install full width cap sheets, lapping 4" (10.2 cm) on the sides and 6" (15.2 cm) on the ends. Stagger adjacent end laps a minimum of 18" (45.7 cm) apart. All side and end laps must be staggered from underlying plies.

All laps must be parallel or perpendicular to the slope of the roof so that the flow of water is never against the lap.

SBS membranes must not be applied during adverse weather or without precautionary measures in temperatures below 45°F (7.1°C). Also refer to Cold Weather Precautions.

Coiled rolls should be unrolled, placed upside down and allowed to "relax" prior to installation. Then reroll to apply.

A minimum 3/8" (10 mm) asphalt flow-out must be obtained at all laps. Do not exceed a maximum 2" (5.2 cm) asphalt flow-out. Dry laps are not acceptable. Check all seams for full and uniform adhesion.

1. The mopping stroke will be such that the side lap is covered with asphalt last. A rolling bank (puddle) of mopping asphalt must be maintained across the full width of the roll.
2. Care should be taken to ensure that the cap sheet lays flat in the asphalt. There must be complete adhesion between the cap sheet and the mopping asphalt. Brooming in may be necessary under certain conditions to ensure that the cap sheet adheres solidly to the asphalt. Apply extra pressure to avoid creating open channels, where three or more membranes are lapped.
3. Check all seams for full and uniform adhesion. Lift all un-adhered seams with a trowel and reseal with USP® 954 Premium Modified Flashing Cement.

All end laps must be staggered a minimum of 18” (45.7 cm) so that no adjacent end laps coincide. If end laps fall in line or are not staggered the proper distance, a full width of SBS membrane must be installed over the end laps.

Cold Adhesive Application: USP® 901 Premium Modified Adhesive are designed to fully adhere the All Weather SBS membrane to the horizontal or low slope substrates under 2” per foot (16 cm per meter).

For slopes greater than 2” per foot (16 cm per meter), USP® 954 Premium Modified Flashing Cement should be used as cold process adhesive for All Weather SBS membrane.

For slopes less than ½” per foot (4 cm per meter), membrane should be applied shingle style, perpendicular to the slope of the roof deck. On all slopes ½” per foot (4 cm per meter) and over membrane should be installed in a strapped fashion or parallel to the slope of the roof.

Backnailing of felts and cap sheet is required when the membrane is installed parallel to the slope.

All laps must be parallel or perpendicular to the slope of the roof so that the flow of water is never against the lap.

SBS membranes must not be applied during adverse weather or without precautionary measures in temperatures below 45°F (7.1°C). Also refer to Cold Weather Precautions.

Coiled rolls should be unrolled, cut into 12’-18’ (3.7-5.5 m) lengths, placed upside down and allowed to “relax” prior to installation. Then reroll to apply.

Install full width sheets, lapping 4” (10.2 cm) on the sides and 6” (15.2 cm) on the ends. Stagger adjacent end laps a minimum of 18” (45 cm) apart. Where installed over base sheet, stagger sheet side and end laps from underlying plies.

A minimum 3/8” (10 mm) and maximum 1” (2.5 cm) cold adhesive flowout must be obtained at all seam areas when the side laps are not heat welded. Dry laps are not acceptable. Check all seams for full and uniform adhesion.

Starting at the low point or the drains, apply the cold adhesive to the substrate as follows:

1. Pour the adhesive on the substrate and spread, using a serrated edged squeegee, applied at the rate of 1-1/2 gal/square (6 L/m²), or spray, using equipment that will apply the adhesive at a rate equal to 1-1/2 gal/square (6 L/m²).
2. Apply the adhesive so that the substrate is coated in a pattern slightly larger than the first sheet being applied:
3. End laps and selvage laps of the SBS being lapped must be coated with adhesive so that a visible bead of adhesive appears. Roll all laps with a weighted roller to ensure proper adhesion. Alternately, the end laps and side laps of the SBS may be heat welded with a hot air welder; this method of application will provide a watertight lap immediately and may be preferable when inclement weather is threatening.
4. Allow 5 to 15 minutes for solvents to evaporate from the adhesive (i.e. tack time or open time) before embedding any sheets into newly applied adhesive. (Note: this is only a guide. Tack times depend on such variables as ambient temperatures, humidity, wind and cloud cover.)
5. Be careful to ensure that the SBS membrane lays flat in the cold adhesive. There must be complete adhesion between the sheet and the cold adhesive. Brooming in may be necessary under certain conditions to ensure that the cap sheet adheres solidly to the cold adhesive. Apply extra pressure to avoid

creating open channels where three or more membranes are lapped.

All end laps must be staggered a minimum of 18” (45.7 cm) so that no adjacent end laps coincide. If end laps fall in line or are not staggered the proper distance, a full width of SBS membrane must be installed over the end laps.

Safety Precautions/Considerations

Roofing is a hazardous construction. Workers should be properly trained in a manner to avoid falls, burns, back injuries, heat related afflictions, etc.

It is the sole responsibility of the roofing applicator to enforce for safety precautions and to ensure safety at all times. All appropriate OSHA and local codes should be followed in the application of roofing. All personnel involved in roofing should be properly trained in safety and fire prevention.

Proper clothing and equipment should be worn at all times on the job site.

We refer you to the National Roofing Contractors Associations’ “Passport to Safety” booklet which addresses numerous safety concerns.

National Roofing Contractors Association
O’Hare International Center
10255 West Higgins Road, Suite 600
Rosemont, IL 60018-5607
(708) 299-9070

READ AND UNDERSTAND ALL WEATHER ROOFING PRODUCTS SPECIFICATION MANUAL before starting application. Follow all precautions and direction.

- Thoroughly train all personnel in the recommended safety procedures for use of kettles, asphalt mopping, propane torches, and for application of product.
- Fire prevention inspections should be conducted periodically during installation, with a final inspection being conducted upon completion of that day’s work.
- Wear personal protective gear. Always use approved safety hard hat, goggles, heavy duty gloves, snug fitting clothing (long pants and long sleeved shirt) and boots. Never allow contact between the heated surface of the product, hot asphalt, open flame and hair, skin or clothing.
- Thoroughly train all personnel on preventing and extinguishing fires. Thoroughly train all personnel in first aid procedures. Always comply with all applicable OSHA safety standards and fire codes.
- Avoid physical contact with product for at least one hour after application to surface.
- Never apply built-up or modified bitumen products directly over exposed conduits or pipes lying on the roof deck.
- Use extreme caution when working around equipment, such as gas lines or HVAC units, which have electrical and/or gas connections.
- Provide in the immediate work area at least one (1) ABC-rated fire extinguisher for each torching device.

Torch Safety Information

Do not install APP torch grade membranes without careful review and implementation of all relevant safety and fire watch requirements including materials/combustible substrates. Review LP-Gas equipment storage and handling guidelines, worker safety precautions and training.

Installation of a roof system is a construction process. As with any construction process safety is a key element; therefore, All Weather Roofing recommends that all applicable safety standards and good roofing practices be followed. Fire prevention is the applicator's responsibility.

Do not allow torching devices to come in contact with flammable materials. The roofing surface, walls, abutments and all surrounding surfaces must be inspected prior to utilization of the torching device so that necessary precautionary measures may be taken.

Keep torch flame moving at all times; failure to do so may result in ignition of surface and/or underlying materials.

Adequate ventilation is required. Maintain sufficient ventilation so that personnel exposures to hazardous concentrations of airborne contaminants are maintained at or below the allowable levels specified by OSHA or NIOSH. Potential oxygen depletion when working in confined spaces must also be taken into consideration.

Avoid prolonged contact with heat sensitive metals such as lead, as overheating of these metal surfaces could ignite underlying flammable surfaces.

The manufacturer's safety and operating instructions provided with the torch system must be followed strictly.

Never use propane except in well ventilated areas. Check all fittings and other equipment on the application equipment for leakage. Never use a flame to check fittings and other equipment. Propane tanks are pressurized. Do not puncture. Do not expose to extreme heat. The tanks must be maintained a minimum safe distance away from the torch flame. Containers which contain or may have contained flammable material must be kept clear from the torch or other heat source.

Always use the base sheet as recommended by the U.S. Ply specifications manual. Failure to do so is extremely hazardous as the base sheet provides an additional protective covering for underlying combustibles. Cant strips used at the roof/wall abutment must be composed of fire retardant material or protected from direct contact with the torch flame.

Application personnel must remain on the job site for a minimum of one (1) hour after completion of installation to inspect for any possible smoldering combustible material. Since fires can result hours after completion of work, periodical inspection thereafter must be made; the time and nature of which will vary depending on the size of the job; the nature of the application surface and abutments, and local code requirements.

Never place a hot torching device on the roof surface, insulation or any other surface or object other than an acceptable stand or holder or fireproof surface.

Never leave a lighted torching device unattended. Never use a torching device to apply any material other than APP modified bituminous membranes and/or SBS modified bituminous membranes that are designed to be torch applied.

Allow torching devices to cool completely to room temperature before removing from the roof.

Application/use of these products may result in burns, and/or other physical injury, surfaces which come in contact with the molten product may become inflamed. Contact with molten asphalt may cause burns.

Statement of practical treatment: in case of skin contact with molten bitumen, apply ice or other cold liquid compatible with skin. Get medical attention immediately.

Cold Weather Precautions

In cooler weather, unrolling and relaxing modified bitumen rolls and base sheet rolls prior to installation will reduce the potential for wrinkles to form in the finished roof. The rolls can be cut into shorter lengths for easier handling when rerolling and installing.

Special care is necessary when installing roof membranes when the ambient temperature and wind chill factor is below 45°F (7.2°C):

1. The roof substrate must be dry. There must be no ice, dew or water. When water in any form is present on the deck, application procedures must be suspended until the deck has dried. Any moisture present at the time the roofing is applied may result in poor adhesion and blistering of the membrane
2. All membrane rolls, adhesives and coatings must be stored, at least overnight, in an area heated at a minimum temperature of 55°F (12.6°C) prior to their application. All water-based coatings must be protected from freezing at all times.
3. Remove rolls from the heated storage only as they are being installed. Install membrane rolls immediately after removal from storage to avoid membrane cooling. Modified rolls must be at least 45°F (7.2°C) at time of application.
4. Because hot asphalt tends to congeal rapidly and lose its adhesive characteristics in cold weather, so extra care must be taken to set insulation or roofing quickly while the asphalt is still hot and fluid. Use the minimum insulation size available. At no time should boards larger than 4' x 4' (1.22 m x 1.22 m) be set in hot asphalt.
5. When hot asphalt is used, the use of an insulated, two-pipe circulating pumping system for asphalt is recommended for minimizing excessive application of asphalt in cold weather and for reducing use of heating fuel. If proper temperatures cannot be maintained in the handling equipment, then roofing should be discontinued.
6. For mop applied membranes, the asphalt temperature at the point of application must be maintained at the asphalt EVT, or 425°F (218°C), whichever is greater; with a rolling bank (puddle) of mopping asphalt across the full width of the roll. Mopping must not precede the roll by more than five feet.
7. Brooming glass felts is critical during cold weather and is mandatory for proper roofing applications.
8. Do not overheat the bitumen to try to offset rapid chilling. If the proper asphalt temperature cannot be consistently maintained, roofing must be discontinued. Be aware that cool, windy conditions will cause asphalt heat loss to occur at a rate equivalent to lower ambient temperatures.
9. During installation, if surface cracking appears in the membrane, discontinue installation immediately and contact.
10. In cooler weather, modified adhesives become more viscous and difficult to apply. Be careful to ensure that the adhesives are applied at the proper rate. The use of blanket warmers or band heaters can help maintain the adhesives at a nominal 70°F (20°C). Do not install cold adhesive in temperatures below 45°F (7.2°C).
11. Do not overheat APP rolls to compensate for cold ambient temperatures. Apply more heat on substrate to properly mate materials. If proper mating adhesion cannot be accomplished then roofing should be discontinued until conditions improve.

Membrane Flashing Application

General: Refer to the construction details in this manual which depict flashing requirements for typically encountered conditions. Install flashing materials as shown in the construction details.

Base flashing for roof systems to be warranted must be a minimum two ply construction.

Wood curbs and walls must be covered with a layer of approved USP® Base sheet or backer ply of selected two-ply flashing system and fastened 8" (20.3 cm) o.c. in all directions with approved fasteners with minimum 1" (25 mm) diameter or square caps.

Backer plies installed over masonry or other non-nailable substrates in hot asphalt must be cut into manageable lengths to ensure adequate adhesion to cant strip and vertical surfaces without excessive voids.

All vertical laps shall be 4" (10.2 cm). Backer ply shall extend out onto field of roof as shown in applicable U.S. Ply construction detail.

Finish ply of selected base flashing detail must be run vertically to maintain selvage edge at all vertical laps.

All vertical laps shall be 3" (7.6 cm) for APP and 4" (10.2 cm) for SBS. Finish ply shall extend out onto field of roof as shown in applicable U.S. Ply construction detail, and must be extended a minimum of 4" (10.2 cm) beyond edge of prior flashing plies. Basic wood blocking anchorage recommendations are found in Factory Mutual Data Sheet 1-49. These recommendations are required for Factory Mutual approved projects.

All penetrations should be at least 18" (45.7 cm) from curbs, walls and edges to provide for proper flashing.

Install flashing sheets starting at low points.

Where indicated by U.S. Ply construction details, install base sheets and backer plies in Type III or IV hot asphalt. Maintain asphalt at $EVT \pm 25^{\circ}F$ (13.9°C) for all bases and ply sheets used in flashing details. Never use solvent based flashing cements, adhesives, mastics and coatings in conjunction with torch grade APP membranes.

Prime all metal and masonry with asphalt primer and allow to dry before being fully adhered with the flashing sheets.

Only use modified bitumen membranes that are designated by U.S. Ply for use as base and wall flashings.

Do not use metal base flashing. Damage to the roofing system caused by metal base flashing is not the responsibility of U.S. Ply.

Base flashing should extend a minimum of 8" (20.3 cm), and a maximum of 24" (61 cm) above the roofline.

Corner membrane flashings, such as "bow ties" for outside corners and "footballs" for inside corners or other membrane reinforcements are required to ensure that base flashing corners are sealed at cant areas. Refer to Flashing Details in this manual.

Note: Mastic and fabric coursing is not an acceptable alternate for proper flashing and counter-flashing details.

Cant strips must be installed at the intersection of the roof and all walls, parapets, curbs, or transitions approaching 90° that are to be flashed. They shall be approximately 4" (10.2 cm) in horizontal and 4" (10.2 cm) in vertical dimension. The face of the cant shall have an incline of not more than 45° with the roof.

Wood cants shall be solid and pressure treated for rot resistance. Perlite based cant strips must comply with ASTM C-728. Do not use fiberboard cants for torch grade installations. Use solid wood cants when mechanical securement to cants is required or when solid wood cants will help stabilize the vertical wood nailers at projections or expansion joint openings.

Masonry cants shall be integrally cast to the wall and deck. They shall be finished and prepared with the same care as the deck. The cant shall be constructed so that it provides a vertical offset equal in thickness to the roof insulation.

Do not use metal cants or metal curb strips.

Cants shall always be installed on top of the roof insulation or wood nailers. Mechanically fasten cant where applicable. Otherwise, set in hot asphalt or low rise, two-component adhesive and install as shown in "Flashing Details", in this manual. Neatly fit all joints and miters.

Wood nailers must be 3-1/2" (8.9 cm) minimum width or 1" (25 mm) wider than metal flange and minimum 1" (25 mm) thick and securely fastened to the deck.

Wood nailers shall be the same thickness as tapered edge strip or insulation.

For roof systems requiring perimeter venting, nailers shall be slotted.

Sheet Metal

General: Metal should not be used as a component of base flashing. Because of the high coefficient of expansion of sheet metals and the large temperature changes that can be experienced on a roof, sheet metal or exposed metal components must be isolated from the waterproofing components of the roofing and flashing system as efficiently as possible to prevent the metal from splitting the membranes. U.S. Ply assumes no responsibility for damage to the roofing system caused by the movement of accessory metal.

When it is unavoidable to use metal in the roofing system (i.e., lead flange at drains, gravel stops), treated wood nailers and insulation stops, 1" (0.5 mm) wider than the metal flange, should be provided for metal flange securement.

For APP roof systems, set metal flange in softened membranes (torch heated), and secure with fasteners of the same type metal as the flange. The metal flange is then sealed using the applicable construction detail to meet warranty requirements.

Metal accessories (gravel stops, counter flashing, etc.) should be a minimum 16 oz. (0.56 mm) copper, 24 gauge (0.71 mm) galvanized or stainless steel, 2 1/2 to 4 lb (1.1- 1.8 kg) lead, or 0.032" (0.81 mm) aluminum.

Fabricate and install all sheet metal materials as shown in applicable construction in the Flashing Detail Section. Refer to SMACNA (Sheet Metal and Air Conditioning Contractors National Association, Inc.) for guidance on sheet metal treatments not addressed in this Manual.

Clean metal and apply asphalt primer to all sheet metal surfaces that will come into contact with asphalt or other bituminous materials; allow the primer adequate time to dry.

Use fastener types compatible with the sheet metal type.

1. Copper or lead-coated copper: use copper or bronze fasteners.
2. Lead and galvanized steel: use galvanized or cadmium-plated sheet fasteners.
3. Aluminum: use aluminum fasteners.
4. Stainless steel: use stainless steel fasteners.

Metal counter-flashing shall have a minimum 4" (10.2 cm) face with a drip lip. The bottom edge of the counter-flashing shall cover the roofing membrane and/or base flashing by a minimum of 4" (10.2 cm). Metal counter-flashing used for masonry walls, wooden walls or through wall metal flashings should be two piece designs to allow for installation and later removal. Metal counter-flashings for stucco, EIFS, wood siding or similar materials should be designed to receive and set as a base for those materials, such as "Z" type flashing, while providing for securement of separate metal counter-flashing to cover base flashings. Metal end joints shall be lapped 3" (7.6 cm) or more. Adequate

fasteners must be provided to secure against effect of wind forces. Skirt fasteners shall be watertight.

Metal termination bars shall be a minimum of 1/10" (3 mm) thick x 1" (2.5 cm) wide with preformed sealant edge lip. Bar should have 1/4" (6 mm) x 3/8" (10 mm) slotted holes on 4" (10.4 cm) centers to facilitate mechanical anchorage.

Note: Termination bars are not suitable in all base flashing and wall flashing conditions. Termination bars may only be used in conjunction with an appropriate counter-flashing extending a minimum of 4" (10.2 cm) below the termination bar.

Metal flanges for gravel stops, eave strips and pitch pockets to be used in conjunction with roofing shall be primed (both sides). For APP roof systems set metal flanges in softened membranes (torch heated), and nail 4" (10.2 cm) o.c. to wood nailers or insulation stops. Flanges shall be a minimum of 3 1/2" (8.9 cm) wide for gravel stops or eave strips and 4" (10.2 cm) wide for projections and extensions through the roof.

The gravel stop or eave strip riser shall be at least 3/8" (10 mm) high for modified bitumen or smooth surface built-up roofing. Total height of riser should be adjusted to extend just above the finished surface, including gravel surfacing if present. Provisions must be made for securing the skirt to the face of the wall. This may be wood nailer strips for masonry and metal construction. In all cases, gravel stop and eave strip nailer, should be fastened to the deck or deck system with adequate resistance against wind forces.

Stacks shall have metal sleeve flashing a minimum 8" (20.3 cm) high. Pitch pockets for brackets, supports, pad-eyes, etc., shall have a 4" (10.2 cm) minimum height metal sleeve.

On reroofing projects, provisions shall be made for reinstallation of existing sheet metal duct work, equipment, coping metal and counter-flashings removed in conjunction with the new work. Also provide for cleaning and repairing of existing defective sheet metal, and replacement of missing and irreparable sheet metal to match existing types. Light gauge sheet metal flashings which are incorporated into the APP roof system are not suitable for re-use and must be replaced with new material.

Conduits and piping such as electrical and gas lines must be set on wood blocking or some other form of support. Wood blocking and supports must be set on All Weather WalkBoards or doubler pads (an additional layer of the roof membrane).

Surfacing Application

Apply roof coating as per coating manufacturer's requirements for application over All Weather membranes. Smooth surfaced membranes must be coated. Reflective coatings must periodically be recoated. Recoating is the responsibility of the owner. The useful life of a given roof coating is generally determined by the type of coating, weather conditions, roof slope and exposure to sunlight and emissivity.

There are three types of surfacing used with modified bitumen membranes:

1. Factory applied mineral granules
2. Aluminum coatings should meet ASTM D2824, Type III.
3. White reflective coatings to meet LEED or Cool Roof requirements.

Walkways

Walkways for normal rooftop traffic can be constructed from two plies of torch grade modified bituminous membranes. This type of walkway is not for sidewalk or patio-type use.

Construct APP walkways after the application of field membrane by solidly torch adhering a layer of All Weather WalkBoard adhering to the surface of the roof membrane

Construct SBS walkways after the application of field membrane by solidly adhering in hot asphalt or cold SBS Flashing Cement a layer of All Weather WalkBoard adhering to the surface of the roof membrane.

Walkway sections should have a 6" (15.2 mm) minimum gap between each section to allow for drainage.

ALL WEATHER SPECIFICATION GUIDE

ALL WEATHER APP SPECIFICATION INDEX					
<i>DECK / SUBSTRATE TYPE</i>	<i>SPECIFICATION NUMBER</i>	<i>CONFIGURATION</i>	<i>SURFACING</i>	<i>RECOMMENDED MINIMUM SLOPE</i>	<i>PAGE NUMBER</i>
NAILABLE	AWAS-2B-N	Base - Smooth APP	SMOOTH	¼"	
	AWAG-2B-N	Base - Granule APP	GRANULATED	¼"	
	AWAG/AWAS-3B-N	Base - Smooth APP - Granule APP	GRANULATED	¼"	
LIGHTWEIGHT CONCRETE	AWAS-2V-LWC	Base - Smooth APP	SMOOTH	¼"	
	AWAG-2V-LWC	Base - Granule APP	GRANULATED	¼"	
	AWAG/AWAS-3B-LWC	Base - Smooth APP - Granule APP	GRANULATED	¼"	
INSULATED	AWAS-2B-I	Insulation - Base - Smooth APP	SMOOTH	¼"	
	AWAG-2B-I	Insulation - Base - Granule APP	GRANULATED	¼"	
	AWAG/AWAS-3B-I	Insulation - Base - Smooth APP - Granule APP	GRANULATED	¼"	
NON-NAILABLE	AWAS-1-NN	Smooth APP	SMOOTH	¼"	
	AWAG-1-NN	Granule APP	GRANULATED	¼"	
	AWAG/AWAS-2-NN	Smooth APP - Granule APP	GRANULATED	¼"	
RECOVER	AWAS-1-RC	Base - Smooth APP	SMOOTH	¼"	
	AWAG-1-RC	Base - Granule APP	GRANULATED	¼"	
	AWAS-2B-RC	Base - Smooth APP	SMOOTH	¼"	
	AWAG-2B-RC	Base - Granule APP	GRANULATED	¼"	
	AWAG/AWAS-3B-RC	Base - Smooth APP - Granule APP	GRANULATED	¼"	
INSULATED RECOVER	AWAS-2B-I-RG	Insulation - Base - Smooth APP	SMOOTH	¼"	
	AWAG-2B-I-RG	Insulation - Base-Granule APP	GRANULATED	¼"	
	AWAG/AWAS-3B-I-RG	Insulation - Base - Smooth APP - Granule APP	GRANULATED	¼"	

ALL WEATHER SBS SPECIFICATION INDEX					
<i>DECK / SUBSTRATE TYPE</i>	<i>SPECIFICATION NUMBER</i>	<i>CONFIGURATION</i>	<i>SURFACING</i>	<i>RECOMMENDED MINIMUM SLOPE</i>	<i>PAGE NUMBER</i>
NAILABLE	AWSG-2B-N	Base - Granule SBS	GRANULATED	¼"	
LIGHTWEIGHT CONCRETE	AWSG-2V-LWC	Base - Granule SBS	GRANULATED	¼"	
INSULATED	AWSG-2B-I-RG	Insulation - Base - Granule SBS	GRANULATED	¼"	
NON-NAILABLE	AWAG-2V-LWC	Base - Granule SBS	GRANULATED	¼"	
RECOVER	AWAG-2V-LWC	Base - Granule SBS	GRANULATED	¼"	
INSULATED RECOVER	AWAG-2B-I-RG	Insulation - Base - Granule SBS	GRANULATED	¼"	

**ALL WEATHER SPECIFICATION KEY
(How to read All Weather Specification Numbers)**

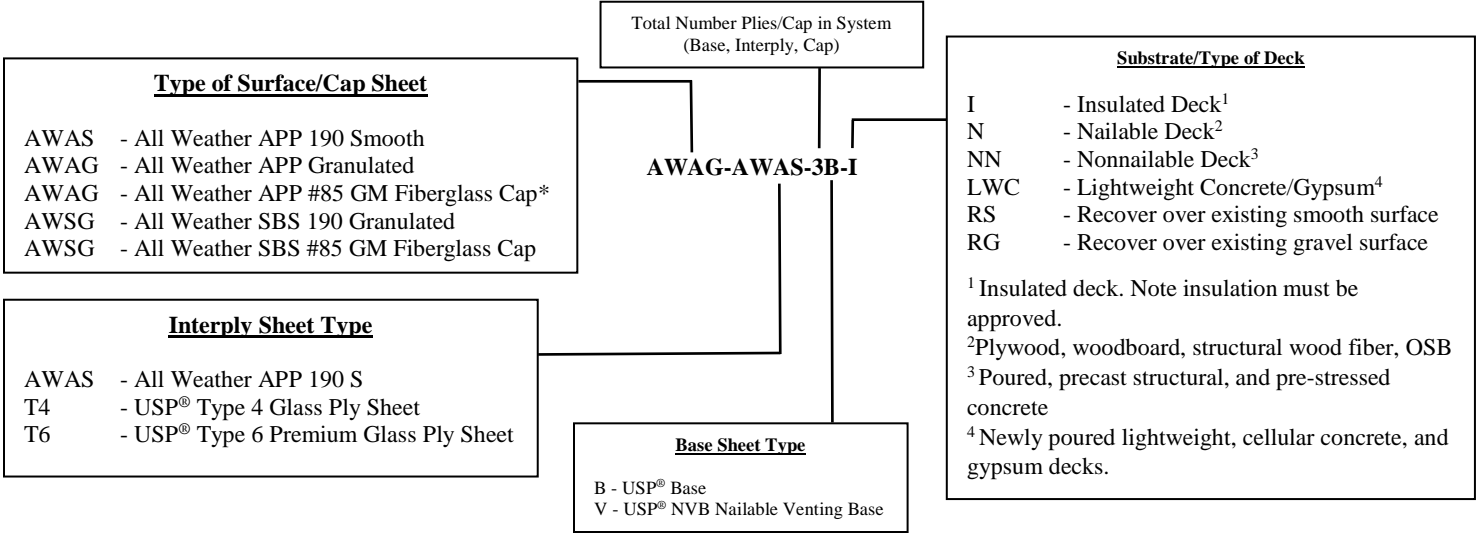

**WHITE: Zone-1
BLACK: Zone-2**

* All Weather APP Glass Cap limited to Zone 2 only.

**All Weather APP / 2 Ply System
Nailable Deck / Lightweight Concrete Deck**

SPECIFICATION NOS: AWAS-2B-N, AWAS-2V-LWC, AWAG-2V-LWC

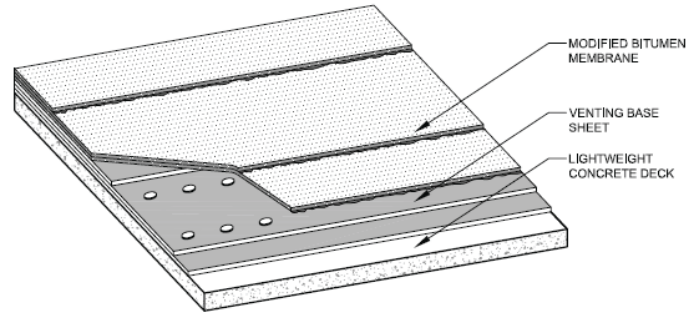
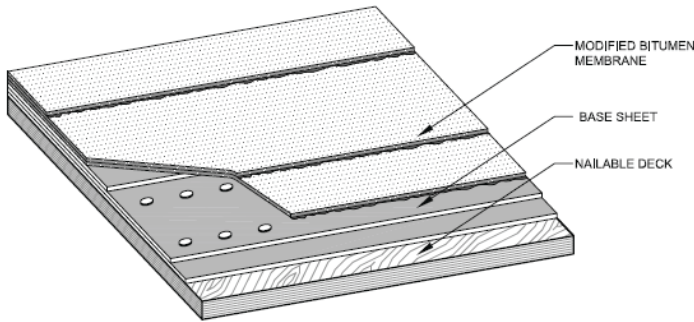

MATERIALS:

Mechanical Fasteners¹ - As required

Base Sheet² – 1 Ply

APP Membrane³ – 1 Ply

Surfacing⁴ – Required over All Weather APP 190 Smooth

- 1 - Use fasteners appropriate for deck type
- 2 - ASTM D 4601 Type II Base, USP® Base, USP® NVB
- 3 - All Weather APP 190 Smooth, All Weather APP #85 GM Fiberglass Cap, All Weather APP 190 Granulated
- 4 - Coating must be compatible with membrane

WARRANTY ELIGIBILITY:

All Weather Limited Material Warranty (no charge)

- Base + All Weather APP #85 GM Fiberglass Cap = 5 Year
- Base + All Weather APP 190 Smooth = 12 Year
- Base + All Weather APP 190 Granulated = 12 Year

Note: All Weather APP #85 GM Fiberglass Cap limited to Zone 2 only.

IMPORTANT: BASE SHEET APPLICATION

Base sheets should be cut into lengths short enough to be easily handled and allowed to warm and relax prior to installation. Appropriate maximum membrane length will vary depending upon temperature conditions. The base sheet must be warmed to a temperature sufficient to allow expansion and relaxation of the asphaltic coating, prior to application, otherwise wrinkles may form. The applicator must evaluate weather conditions to determine maximum functional length and relaxation time to avoid wrinkling. Place tension on the end of the base sheet during installation to ensure that the sheet lays flat.

APPLICATION RECOMMENDATIONS

ROOF DECK shall be firm, clean, dry and smooth. All membranes shall be applied so the flow of water is over or parallel to, but never against the laps.

BASE SHEET: Select appropriate base sheet for deck type. Mechanically fasten base sheet over the deck. Lap the base sheet a minimum of 2” (5.1 cm) of sides and 4” (10.2 cm) on ends, and mechanically fasten with appropriate fasteners. Follow pattern determined by warranty requirements or by design criteria whichever is more stringent. Increase fastener density in perimeters and corners in accordance with project requirements.

APP MEMBRANE: Set and align rolls before application with at least 3” (7.6 cm) side laps and 6” (15.3 cm) end laps. Adjacent end laps shall be staggered 18” (45.7 cm). Stagger laps between the base ply and APP membrane. Apply sufficient heat, with a torch, to the back of the sheet to melt the asphalt to a semi-liquid state, while heating the base at the same time. A minimum of 3/8” (10 mm) compound flow-out must be obtained at all seam areas. Do not exceed a maximum 1” (25 mm) compound flow-out. Roll sheet into place, applying pressure with foot or roller on all laps immediately after rolling in. Apply extra pressure to avoid creating open channels, where three or more membranes are lapped.

BASE FLASHING: APP roof systems must be flashed according to All Weather APP Flashing Details (See Appendix).

SURFACING: Granulated surfacing requires the use of All Weather APP 190 Granulated or All Weather APP #85 GM Fiberglass Cap and specification number AWAG-2B-N for nailable decks and AWAG-2V-LWC for lightweight concrete and gypsum decks. Smooth surfacing utilizes All Weather APP 190 Smooth and specification number AWAS-2B-N for nailable decks and AWAS-2V-LWC for lightweight and gypsum decks. APP 190 Smooth must be coated with a roof coating. All reflective coatings require periodic recoating, which is the responsibility of the owner. The roof coating must be maintained in satisfactory condition to maintain the All Weather warranty coverage.

CAUTION: Application of APP membranes utilizes open flame from a torch. Improper use of a torch can result in physical injury as well as damage to property. Surfaces or structures which come in contact with the molten product or the open flame may catch fire or the applicator may suffer burns. Follow all local fire codes; have proper fire extinguishers in working condition, on the roof and readily available. See Safety Precautions/Considerations on page 20.

All Weather APP / 2 Ply System Insulated Deck

SPECIFICATION NOS: AWAS-2B-I, AWAG-2B-I

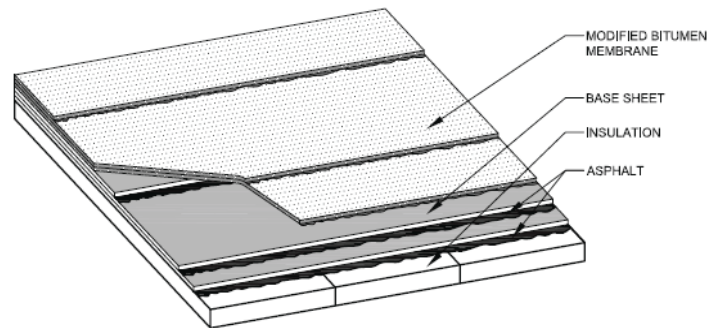
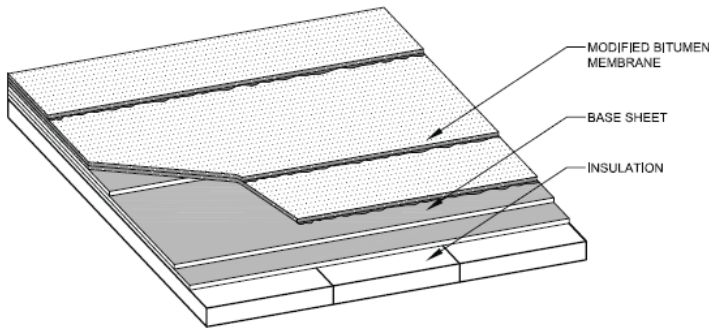

MATERIALS:

- Approved Insulation¹ - As required
- Mechanical Fasteners² - As required
- Base Sheet³ – 1 Ply
- APP Membrane⁴ – 1 Ply
- Surfacing⁵ – Required over All Weather APP 190 Smooth
- 1 - Use insulation as approved by All Weather
- 2 - Use fasteners appropriate for deck type
- 3 - ASTM D 4601 Type II Base, USP® Base, USP® NVB
- 4 - All Weather APP 190 Smooth, All Weather APP #85 GM Fiberglass Cap, All Weather APP 190 Granulated
- 5 - Coating must be compatible with membrane

WARRANTY ELIGIBILITY:

All Weather Limited Material Warranty (no charge)

- Base + All Weather APP #85 GM Fiberglass Cap = 5 Year
- Base + All Weather APP 190 Smooth = 12 Year
- Base + All Weather APP 190 Granulated = 12 Year

Note: All Weather APP #85 GM Fiberglass Cap limited to Zone 2 only.

APPLICATION RECOMMENDATIONS

ROOF DECK shall be firm, clean, dry and smooth. All membranes shall be applied so the flow of water is over or parallel to, but never against the laps.

WOOD INSULATION STOPS the same thickness as the insulation, should be attached at outside edges and openings through the deck. These stops shall be 6” (15 cm) wide or 1” (25 mm) wider than flanges being nailed to them.

BASE SHEET:

Option 1: Select appropriate base sheet for deck type. Insulation and base sheet are fastened simultaneously. Mechanically fasten one ply of base sheet over the loose laid insulation. Lap sheets a minimum 2” (5 cm) on side laps and 4” (10 cm) on the end laps. Appropriate screws and plates are then installed per pattern determined by warranty requirements or by design criteria whichever is more stringent. Increase fastener density in perimeters and corners in accordance with project requirements.

Option 2: Install base sheet, over insulation system, in a uniform mopping of hot asphalt applied at the rate of 25 lb/square (1.2 kg/m²). Lap the sheets 2” (5 cm) on side laps and 4” (10 cm) on end laps.

APP MEMBRANE: Set and align rolls before application with at least 3” (7.6 cm) side laps and 6” (10.2 cm) end laps. Adjacent end laps shall be staggered 18” (45.7 cm). Stagger laps between the base ply and APP membrane. Apply sufficient heat, with a torch, to the back of the sheet to melt the asphalt to a semi-liquid state, while heating the base at the same time. A minimum of 3/8” (10 mm) compound flow-out must be obtained at all seam areas. Do not exceed a maximum 1” (25 mm) compound flow-out. Roll sheet into place, applying pressure with foot or roller on all laps immediately after rolling in. Apply extra pressure to avoid creating open channels, where three or more membranes are lapped.

BASE FLASHING: APP roof systems must be flashed according to All Weather APP Flashing Details (See Appendix).

SURFACING: Mineral surfacing requires the use of All Weather APP 190 Granulated or All Weather APP #85 GM Fiberglass Cap and specification number AWAG-2B-I. Smooth surfacing utilizes All Weather APP 190 Smooth and specification number AWAS-2B-I. Smooth surface APP must be coated with a roof coating. All reflective coatings require periodic recoating, which is the responsibility of the owner. The roof coating must be maintained in satisfactory condition to maintain the All Weather warranty coverage.

CAUTION: Application of APP membranes utilizes open flame from a torch. Improper use of a torch can result in physical injury as well as damage to property. Surfaces or structures which come in contact with the molten product or the open flame may catch fire or the applicator may suffer burns. Follow all local fire codes; have proper fire extinguishers in working condition, on the roof and readily available. See Safety Precautions/Considerations on page 20.

IMPORTANT: BASE SHEET APPLICATION

Base sheets should be cut into lengths short enough to be easily handled and allowed to warm and relax prior to installation. Appropriate maximum membrane length will vary depending upon temperature conditions. The base sheet must be warmed to a temperature sufficient to allow expansion and relaxation of the asphaltic coating, prior to application, otherwise wrinkles may form. The applicator must evaluate weather conditions to determine maximum functional length and relaxation time to avoid wrinkling. Place tension on the end of the base sheet during installation to ensure that the sheet lays flat.

**All Weather APP / 1 Ply System
Non-Nailable Deck / Concrete Deck**

SPECIFICATION NOS: AWAS-1-NN, AWAG-1-NN

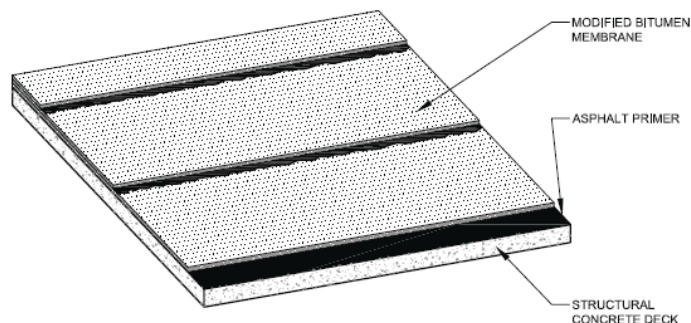

MATERIALS:

Asphalt Primer – 1 gal/square (0.4 L/m²)

APP Membrane¹ – 1 Ply

Surfacing² – Required over All Weather APP 190 Smooth

- ¹ - All Weather APP 190 Smooth, All Weather APP #85 GM Fiberglass Cap, All Weather APP 190 Granulated
- ² - Coating must be compatible with membrane

WARRANTY ELIGIBILITY:

All Weather Limited Material Warranty (no charge)

- All Weather APP #85 GM Fiberglass Cap = 5 Year
- All Weather APP 190 Smooth = 12 Year
- All Weather APP 190 Granulated = 12 Year

Note: All Weather APP #85 GM Fiberglass Cap limited to Zone 2 only.

APPLICATION RECOMMENDATIONS

ROOF DECK shall be firm, clean, dry and smooth. All membranes shall be applied so the flow of water is over or parallel to, but never against the laps.

PRIME the deck with asphalt primer applied at the rate of 1 gal/square (0.4 L/m²). Hold primer back 6” (15 cm) from concrete deck joints.

APP MEMBRANE: Set and align rolls before application with at least 3” (7.6 cm) side laps and 6” (10.2 cm) end laps. Adjacent end laps shall be staggered 18” (45.7 cm). Apply sufficient heat, with a torch, to the back of the sheet to melt the asphalt to a semi-liquid state, while heating the base at the same time. A minimum of 3/8” (10 mm) compound flow-out must be obtained at all seam areas. Do not exceed a maximum 1” (25 mm) compound flow-out. Roll sheet into place, applying pressure with foot or roller on all laps immediately after rolling in. Apply extra pressure to avoid creating open channels, where three or more membranes are lapped.

BASE FLASHING: APP roof systems must be flashed according to All Weather APP Flashing Details (See Appendix).

SURFACING: Mineral surfacing requires the use of All Weather APP 190 Granulated or All Weather APP #85 GM Fiberglass Cap and specification number AWAG-1-NN for non-nailable decks. Smooth surfacing utilizes All Weather APP 190 Smooth and specification number AWAS-1-NN for non-nailable decks. Smooth surface APP must be coated with a roof coating. All reflective coatings require periodic recoating, which is the responsibility of the owner. The roof coating must be maintained in satisfactory condition to maintain the All Weather warranty coverage.

CAUTION: Application of APP membranes utilizes open flame from a torch. Improper use of a torch can result in physical injury as well as damage to property. Surfaces or structures which come in contact with the molten product or the open flame may catch fire or the applicator may suffer burns. Follow all local fire codes; have proper fire extinguishers in working condition, on the roof and readily available. See Safety Precautions/Considerations on page 20.

**All Weather APP / 3 Ply System
Nailable Deck / Lightweight Concrete Deck**

SPECIFICATION NOS. AWAG-AWAS-3B-N, AWAG-AWAS-3V-LWC

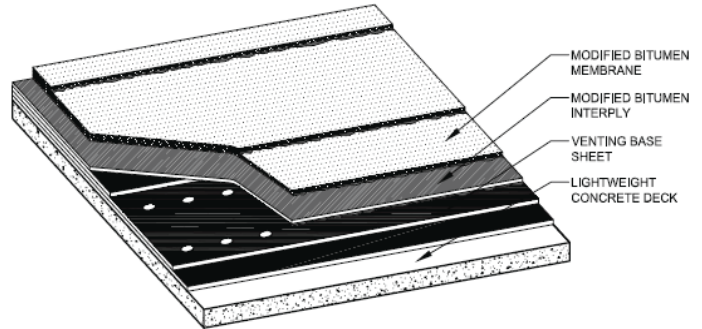
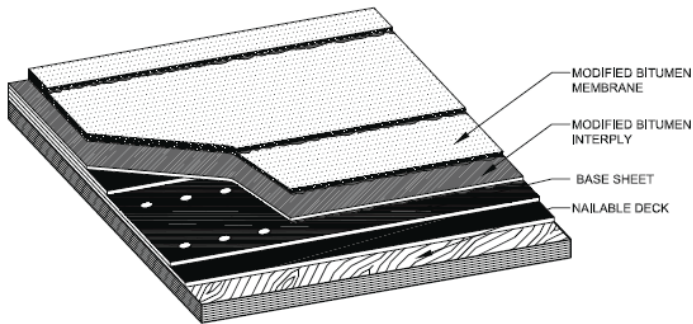

MATERIALS:

- Mechanical Fasteners¹ - As required
- Base Sheet² – 1 Ply
- APP Interply Membrane³ – 1 Ply
- APP Membrane⁴ – 1 Ply

- 1 - Use fasteners appropriate for deck type
- 2 - ASTM D 4601 Type II Base, USP® Base, USP® NVB
- 3 - All Weather APP 190 Smooth
- 4 - All Weather APP 190 Granulated

WARRANTY ELIGIBILITY:

All Weather Limited Material Warranty (no charge)

- Base + All Weather APP 190 Smooth + All Weather APP 190 Granulated = 12 Year

APPLICATION RECOMMENDATIONS

ROOF DECK shall be firm, clean, dry and smooth. All membranes shall be applied so the flow of water is over or parallel to, but never against the laps.

BASE SHEET: Select appropriate base sheet for deck type. Mechanically fasten base sheet over the deck. Lap the base sheet a minimum of 2” (5.1 cm) of sides and 4” (10.2 cm) on ends, and mechanically fasten with appropriate fasteners. Follow pattern determined by warranty requirements or by design criteria whichever is more stringent. Increase fastener density in perimeters and corners in accordance with project requirements.

APP INTERPLY MEMBRANE: Set and align rolls before application with at least 3” (7.6 cm) side laps and 6” (15.3 cm) end laps. Adjacent end laps shall be staggered 18” (45.7 cm). Apply sufficient heat, with a torch, to the back of the sheet to melt the asphalt to a semi-liquid state, while heating the base at the same time. A minimum of 3/8” (10 mm) compound flow-out must be obtained at all seam areas. Do not exceed a maximum 1” (25 mm) compound flow-out. Roll sheet into place, applying pressure with foot or roller on all laps immediately after rolling in. Apply extra pressure to avoid creating open channels, where three or more membranes are lapped.

APP MEMBRANE: Set and align rolls before application with at least 3” (7.6 cm) side laps and 6” (15.3 cm) end laps. Adjacent end laps shall be staggered 18” (45.7 cm). Stagger laps between the underlying ply and APP membrane. Apply sufficient heat, with a torch, to the back of the sheet to melt the asphalt to a semi-liquid state, while heating the base at the same time. A minimum of 3/8” (10 mm) compound flow-out must be obtained at all seam areas. Do not exceed a maximum 1” (25 mm) compound flow-out. Roll sheet into place, applying pressure with foot or roller on all laps immediately after rolling in. Apply extra pressure to avoid creating open channels, where three or more membranes are lapped.

BASE FLASHING: APP roof systems must be flashed according to All Weather APP Flashing Details (See Appendix).

CAUTION: Application of APP membranes utilizes open flame from a torch. Improper use of a torch can result in physical injury as well as damage to property. Surfaces or structures which come in contact with the molten product or the open flame may catch fire or the applicator may suffer burns. Follow all local fire codes; have proper fire extinguishers in working condition, on the roof and readily available. See Safety Precautions/Considerations on page 20.

IMPORTANT: BASE SHEET APPLICATION
Base sheets should be cut into lengths short enough to be easily handled and allowed to warm and relax prior to installation. Appropriate maximum membrane length will vary depending upon temperature conditions. The base sheet must be warmed to a temperature sufficient to allow expansion and relaxation of the asphaltic coating, prior to application, otherwise wrinkles may form. The applicator must evaluate weather conditions to determine maximum functional length and relaxation time to avoid wrinkling. Place tension on the end of the base sheet during installation to ensure that the sheet lays flat.

All Weather APP / 3 Ply System Insulated Deck

SPECIFICATION NOS: AWAG-AWAS-3B-I

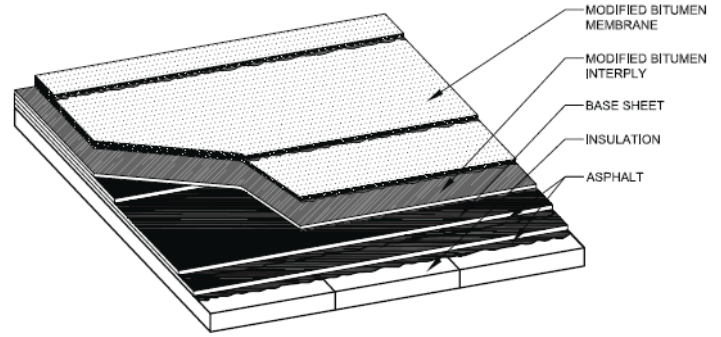
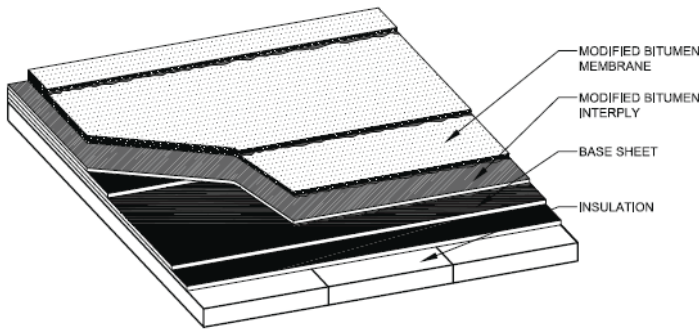

MATERIALS:

- Approved Insulation¹ - As required
- Mechanical Fasteners² - As required
- Base Sheet³ – 1 Ply
- APP Interply⁴ - Membrane – 1 Ply
- APP Membrane⁵ – 1 Ply

- 1 - Use insulation as approved by All Weather
- 2 - Use fasteners appropriate for deck type
- 3 - ASTM D 4601 Type II Base, USP® Base, USP® NVB
- 4 - All Weather APP 190 Smooth
- 5 - All Weather APP 190 Granulated

WARRANTY ELIGIBILITY:

All Weather Limited Material Warranty (no charge)

- Base + All Weather APP 190 Smooth + All Weather APP 190 Granulated = 12 Year

IMPORTANT: BASE SHEET APPLICATION

Base sheets should be cut into lengths short enough to be easily handled and allowed to warm and relax prior to installation. Appropriate maximum membrane length will vary depending upon temperature conditions. The base sheet must be warmed to a temperature sufficient to allow expansion and relaxation of the asphaltic coating, prior to application, otherwise wrinkles may form. The applicator must evaluate weather conditions to determine maximum functional length and relaxation time to avoid wrinkling. Place tension on the end of the base sheet during installation to ensure that the sheet lays flat.

APPLICATION RECOMMENDATIONS

ROOF DECK shall be firm, clean, dry and smooth. All membranes shall be applied so the flow of water is over or parallel to, but never against the laps.

WOOD INSULATION STOPS the same thickness as the insulation, should be attached at outside edges and openings through the deck. These stops shall be 6” (15 cm) wide or 1” (25 mm) wider than flanges being nailed to them.

BASE SHEET: Option 1: Select appropriate base sheet for deck type. Insulation and base sheet are fastened simultaneously. Mechanically fasten one ply of base sheet over the loose laid insulation. Lap sheets a minimum 2” (5 cm) on side laps and 4” (10 cm) on the end laps. Appropriate screws and plates are then installed per pattern determined by warranty requirements or by design criteria whichever is more stringent. Increase fastener density in perimeters and corners in accordance with project requirements. **Option 2:** Install base sheet, over insulation system, in a uniform mopping of hot asphalt applied at the rate of 25 lb/square (1.2 kg/m²). Lap the sheets 2” (5 cm) on side laps and 4” (10 cm) on end laps.

APP INTERPLY MEMBRANE: Set and align rolls before application with at least 3” (7.6 cm) side laps and 6” (15.3 cm) end laps. Adjacent end laps shall be staggered 18” (45.7 cm). Apply sufficient heat, with a torch, to the back of the sheet to melt the asphalt to a semi-liquid state, while heating the base at the same time. A minimum of 3/8” (10 mm) compound flow-out must be obtained at all seam areas. Do not exceed a maximum 1” (25 mm) compound flow-out. Roll sheet into place, applying pressure with foot or roller on all laps immediately after rolling in. Apply extra pressure to avoid creating open channels, where three or more membranes are lapped.

APP MEMBRANE: Set and align rolls before application with at least 3” (7.6 cm) side laps and 6” (10.2 cm) end laps. Adjacent end laps shall be staggered 18” (45.7 cm). Stagger laps between the underlying ply and APP membrane. Apply sufficient heat, with a torch, to the back of the sheet to melt the asphalt to a semi-liquid state, while heating the base at the same time. A minimum of 3/8” (10 mm) compound flow-out must be obtained at all seam areas. Do not exceed a maximum 1” (25 mm) compound flow-out. Roll sheet into place, applying pressure with foot or roller on all laps immediately after rolling in. Apply extra pressure to avoid creating open channels, where three or more membranes are lapped.

BASE FLASHING: APP roof systems must be flashed according to All Weather APP Flashing Details (See Appendix).

CAUTION: Application of APP membranes utilizes open flame from a torch. Improper use of a torch can result in physical injury as well as damage to property. Surfaces or structures which come in contact with the molten product or the open flame may catch fire or the applicator may suffer burns. Follow all local fire codes; have proper fire extinguishers in working condition, on the roof and readily available. See Safety Precautions/Considerations on page 20.

**All Weather APP / 2 Ply System
Non-Nailable Deck / Concrete Deck**

SPECIFICATION NOS. AWAG-AWAS-2-NN

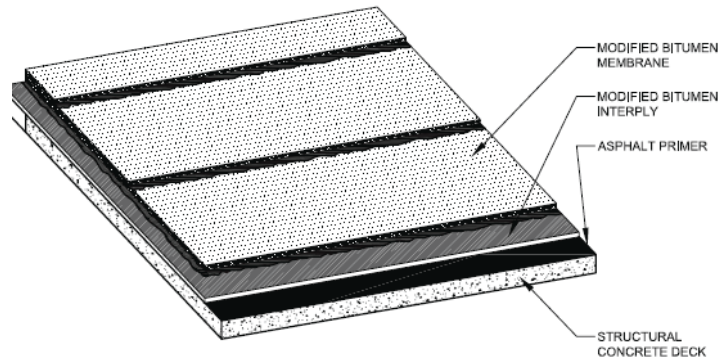

MATERIALS:

- Asphalt Primer – 1 gal/square (0.4 L/m²)
- APP Base Membrane¹ – 1 Ply
- APP Membrane² – 1 Ply
- ¹ - All Weather APP 190 Smooth
- ² - All Weather APP 190 Granulated

WARRANTY ELIGIBILITY:

All Weather Limited Material Warranty (no charge)

- All Weather APP 190 Smooth + All Weather APP 190 Granulated = 12 Year

APPLICATION RECOMMENDATIONS

ROOF DECK shall be firm, clean, dry and smooth. All membranes shall be applied so the flow of water is over or parallel to, but never against the laps.

PRIME the deck with asphalt primer applied at the rate of 1 gal/square (0.4 L/m²). Hold primer back 6” (15 cm) from concrete deck joints.

APP BASE MEMBRANE: Set and align rolls before application with at least 3” (7.6 cm) side laps and 6” (15.3 cm) end laps. Adjacent end laps shall be staggered 18” (45.7 cm). Apply sufficient heat, with a torch, to the back of the sheet to melt the asphalt to a semi-liquid state, while heating the primed substrate at the same time. A minimum of 3/8” (10 mm) compound flow-out must be obtained at all seam areas. Do not exceed a maximum 1” (25 mm) compound flow-out. Roll sheet into place, applying pressure with foot or roller on all laps immediately after rolling in. Apply extra pressure to avoid creating open channels, where three or more membranes are lapped.

APP MEMBRANE: Set and align rolls before application with at least 3” (7.6 cm) side laps and 6” (10.2 cm) end laps. Adjacent end laps shall be staggered 18” (45.7 cm). Stagger laps between the underlying ply and APP membrane. Apply sufficient heat, with a torch, to the back of the sheet to melt the asphalt to a semi-liquid state, while heating the base at the same time. A minimum of 3/8” (10 mm) compound flow-out must be obtained at all seam areas. Do not exceed a maximum 1” (25 mm) compound flow-out. Roll sheet into place, applying pressure with foot or roller on all laps immediately after rolling in. Apply extra pressure to avoid creating open channels, where three or more membranes are lapped.

BASE FLASHING: APP roof systems must be flashed according to All Weather APP Flashing Details (See Appendix).

CAUTION: Application of APP membranes utilizes open flame from a torch. Improper use of a torch can result in physical injury as well as damage to property. Surfaces or structures which come in contact with the molten product or the open flame may catch fire or the applicator may suffer burns. Follow all local fire codes; have proper fire extinguishers in working condition, on the roof and readily available. See Safety Precautions/Considerations on page 20.

All Weather APP / 1 or 2 Ply System Recover Over Existing Smooth Surface Roof

SPECIFICATION NOS: AWAS-1-RC, AWAG-1-RC, AWAS-2B-RC, AWAG-2B-RC

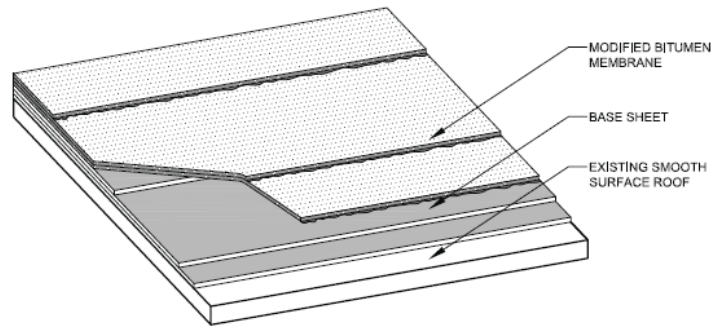
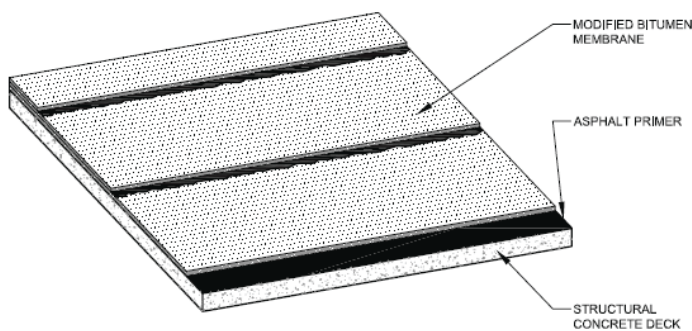

MATERIALS:

Mechanical Fasteners¹ - As required

Base Sheet² – 1 Ply

APP Membrane³ – 1 Ply

Surfacing⁴ – Required over All Weather APP 190 Smooth

- ¹ - Use fasteners appropriate for deck type
- ² - ASTM D 4601 Type II Base, USP® Base, USP® NVB
- ³ - All Weather APP 190 Smooth, All Weather APP #85 GM Fiberglass Cap, All Weather APP 190 Granulated
- ⁴ - Coating must be compatible with membrane

WARRANTY ELIGIBILITY:

All Weather Limited Material Warranty (no charge)

- Base + All Weather APP #85 GM Fiberglass Cap = 5 Year
- Base + All Weather APP 190 Smooth = 12 Year
- Base + All Weather APP 190 Granulated = 12 Year

Note: All Weather APP #85 GM Fiberglass Cap limited to Zone 2 only.

IMPORTANT: BASE SHEET APPLICATION

Base sheets should be cut into lengths short enough to be easily handled and allowed to warm and relax prior to installation. Appropriate maximum membrane length will vary depending upon temperature conditions. The base sheet must be warmed to a temperature sufficient to allow expansion and relaxation of the asphaltic coating, prior to application, otherwise wrinkles may form. The applicator must evaluate weather conditions to determine maximum functional length and relaxation time to avoid wrinkling. Place tension on the end of the base sheet during installation to ensure that the sheet lays flat.

APPLICATION RECOMMENDATIONS

NOTE: Base sheet is optional when the existing smooth surface roof is in good condition and the attachment of the existing roof is not in doubt. Specification number AWAS-2B-RC changes to AWAS-1-RC and AWAG-2B-RC changes to AWAG-1-RC.

ROOF SUBSTRATE shall be firm, clean, dry and smooth. All membranes shall be applied so the flow of water is over or parallel to, but never against the laps.

BASE SHEET (if required): Select appropriate base sheet for deck type. Mechanically fasten base sheet over the deck. Lap the base sheet a minimum of 2” (5.1 cm) of sides and 4” (10.2 cm) on ends, and mechanically fasten with appropriate fasteners. Follow pattern determined by warranty requirements or by design criteria whichever is more stringent. Increase fastener density in perimeters and corners in accordance with project requirements.

APP MEMBRANE: Set and align rolls before application with at least 3” (7.6 cm) side laps and 6” (15.3 cm) end laps. Adjacent end laps shall be staggered 18” (45.7 cm). Stagger laps between the base ply and APP membrane. Apply sufficient heat, with a torch, to the back of the sheet to melt the asphalt to a semi-liquid state, while heating the base at the same time. A minimum of 3/8” (10 mm) compound flow-out must be obtained at all seam areas. Do not exceed a maximum 1” (25 mm) compound flow-out. Roll sheet into place, applying pressure with foot or roller on all laps immediately after rolling in. Apply extra pressure to avoid creating open channels, where three or more membranes are lapped.

BASE FLASHING: APP roof systems must be flashed according to All Weather APP Flashing Details (See Appendix).

SURFACING: Mineral surfacing requires the use of All Weather APP 190 Granulated or All Weather APP Glass Cap and specification number AWAG-2B-RC. Smooth surfacing utilizes All Weather APP 190 Smooth and specification number AWAS-2B-RC. Smooth surface APP must be coated with a roof coating. All reflective coatings require periodic recoating, which is the responsibility of the owner. The roof coating must be maintained in satisfactory condition to maintain the All Weather warranty coverage.

CAUTION: Application of APP membranes utilizes open flame from a torch. Improper use of a torch can result in physical injury as well as damage to property. Surfaces or structures which come in contact with the molten product or the open flame may catch fire or the applicator may suffer burns. Follow all local fire codes; have proper fire extinguishers in working condition, on the roof and readily available. See Safety Precautions/Considerations on page 20.

All Weather APP / 3 Ply System Recover Over Existing Smooth Surface Roof

SPECIFICATION NOS: AWAG-AWAS-3B-RC

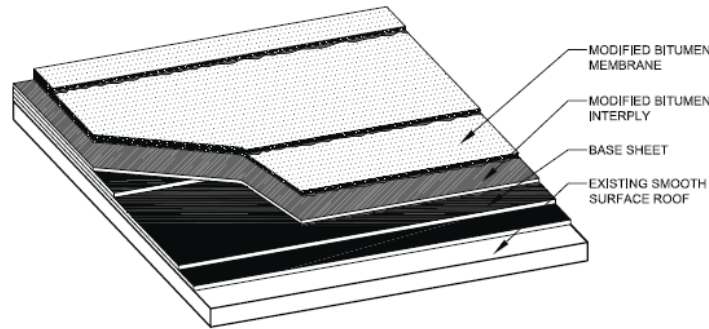

MATERIALS:

Mechanical Fasteners¹ - As required
Base Sheet² – 1 Ply
APP Interply³ – 1 Ply
APP Membrane⁴ – 1 Ply

- 1 - Use fasteners appropriate for deck type
- 2 - ASTM D 4601 Type II Base, USP® Base, USP® NVB
- 3 - All Weather APP 190 Smooth
- 4 - All Weather APP 190 Granulated

WARRANTY ELIGIBILITY:

All Weather Limited Material Warranty (no charge)

- All Weather APP 190 Smooth + All Weather APP 190 Granulated = 12 Year

IMPORTANT: BASE SHEET APPLICATION

Base sheets should be cut into lengths short enough to be easily handled and allowed to warm and relax prior to installation. Appropriate maximum membrane length will vary depending upon temperature conditions. The base sheet must be warmed to a temperature sufficient to allow expansion and relaxation of the asphaltic coating, prior to application, otherwise wrinkles may form. The applicator must evaluate weather conditions to determine maximum functional length and relaxation time to avoid wrinkling. Place tension on the end of the base sheet during installation to ensure that the sheet lays flat.

APPLICATION RECOMMENDATIONS

NOTE: Base sheet is optional when the existing smooth surface roof is in good condition and the attachment of the existing roof is not in doubt. Specification number AWAS-2B-RC changes to AWAS-1-RC and AWAG-2B-RC changes to AWAG-1-RC.

ROOF SUBSTRATE shall be firm, clean, dry and smooth. All membranes shall be applied so the flow of water is over or parallel to, but never against the laps.

BASE SHEET (if required): Select appropriate base sheet for deck type. Mechanically fasten base sheet over the deck. Lap the base sheet a minimum of 2" (5.1 cm) of sides and 4" (10.2 cm) on ends, and mechanically fasten with appropriate fasteners. Follow pattern determined by warranty requirements or by design criteria whichever is more stringent. Increase fastener density in perimeters and corners in accordance with project requirements.

APP INTERPLY MEMBRANE: Set and align rolls before application with at least 3" (7.6 cm) side laps and 6" (15.3 cm) end laps. Adjacent end laps shall be staggered 18" (45.7 cm). Apply sufficient heat, with a torch, to the back of the sheet to melt the asphalt to a semi-liquid state, while heating the base at the same time. A minimum of 3/8" (10 mm) compound flow-out must be obtained at all seam areas. Do not exceed a maximum 1" (25 mm) compound flow-out. Roll sheet into place, applying pressure with foot or roller on all laps immediately after rolling in. Apply extra pressure to avoid creating open channels, where three or more membranes are lapped.

APP MEMBRANE: Set and align rolls before application with at least 3" (7.6 cm) side laps and 6" (15.3 cm) end laps. Adjacent end laps shall be staggered 18" (45.7 cm). Stagger laps between the underlying ply and APP membrane. Apply sufficient heat, with a torch, to the back of the sheet to melt the asphalt to a semi-liquid state, while heating the base at the same time. A minimum of 3/8" (10 mm) compound flow-out must be obtained at all seam areas. Do not exceed a maximum 1" (25 mm) compound flow-out. Roll sheet into place, applying pressure with foot or roller on all laps immediately after rolling in. Apply extra pressure to avoid creating open channels, where three or more membranes are lapped.

BASE FLASHING: APP roof systems must be flashed according to All Weather APP Flashing Details (See Appendix).

CAUTION: Application of APP membranes utilizes open flame from a torch. Improper use of a torch can result in physical injury as well as damage to property. Surfaces or structures which come in contact with the molten product or the open flame may catch fire or the applicator may suffer burns. Follow all local fire codes; have proper fire extinguishers in working condition, on the roof and readily available. See Safety Precautions/Considerations on page 20.

All Weather APP / 2 Ply System Over Existing Gravel Surface Roof

SPECIFICATION NOS: AWAS-2B-I-RG, AWAG-2B-I-RG

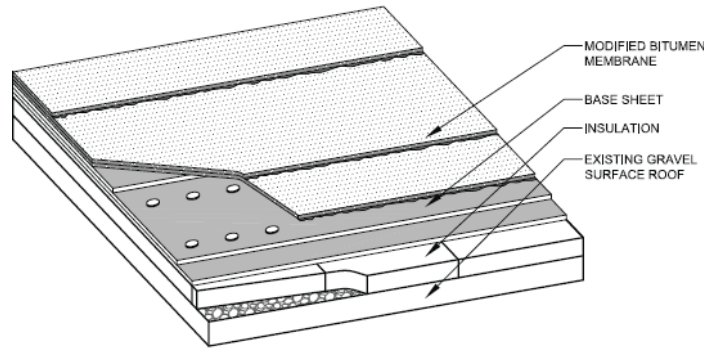

MATERIALS:

Approved Insulation¹ - As required
Mechanical Fasteners² - As required
Base Sheet³ – 1 Ply
APP Membrane⁴ – 1 Ply
Surfacing⁵ – Required over All Weather APP 190 Smooth

- 1 - Use insulation as approved by All Weather
- 2 - Use fasteners appropriate for deck type
- 3 - ASTM D 4601 Type II Base, USP® Base, USP® NVB
- 4 - All Weather APP 190 Smooth, All Weather APP #85 GM Fiberglass Cap, All Weather APP 190 Granulated
- 5 - Coating must be compatible with membrane

WARRANTY ELIGIBILITY:

All Weather Limited Material Warranty (no charge)

- Base + All Weather APP #85 GM Fiberglass Cap = 5 Year
- Base + All Weather APP 190 Smooth = 12 Year
- Base + All Weather APP 190 Granulated = 12 Year

Note: All Weather APP #85 GM Fiberglass Cap limited to Zone 2 only.

IMPORTANT: BASE SHEET APPLICATION

Base sheets should be cut into lengths short enough to be easily handled and allowed to warm and relax prior to installation. Appropriate maximum membrane length will vary depending upon temperature conditions. The base sheet must be warmed to a temperature sufficient to allow expansion and relaxation of the asphaltic coating, prior to application, otherwise wrinkles may form. The applicator must evaluate weather conditions to determine maximum functional length and relaxation time to avoid wrinkling. Place tension on the end of the base sheet during installation to ensure that the sheet lays flat.

APPLICATION RECOMMENDATIONS

ROOF SUBSTRATE shall be swept, free of loose gravel and otherwise properly prepared prior to insulation installation.

ROOF INSULATION: shall be applied in approved manner. **Option 1:** Loose lay insulation with joints staggered in one direction over the existing roof for simultaneous base sheet attachment. **Option 2:** Mechanically fasten insulation through the existing roof to the deck with joints staggered in one direction.

BASE SHEET: Option 1: Select appropriate base sheet for deck type. Insulation and base sheet are fastened simultaneously. Mechanically fasten one ply of base sheet over the loose laid insulation. Lap sheets 2” (5 cm) on side laps and 4” (10 cm) on the end laps. Appropriate screws and plates are then installed per pattern determined by warranty requirements or by design criteria whichever is more stringent. Increase fastener density in perimeters and corners in accordance with project requirements. **Option 2:** Install base sheet, over insulation, in a uniform mopping of hot asphalt applied at the rate of 25 lb/square (1.2 kg/m²). Lap the sheets 2” (5 cm) on side laps and 4” (10 cm) on end laps.

APP MEMBRANE: Set and align rolls before application with at least 3” (7.6 cm) side laps and 6” (15.3 cm) end laps. Adjacent end laps shall be staggered 18” (45.7 cm). Stagger laps between the base ply and APP membrane. Apply sufficient heat, with a torch, to the back of the sheet to melt the asphalt to a semi-liquid state, while heating the base at the same time. A minimum of 3/8” (10 mm) compound flow-out must be obtained at all seam areas. Do not exceed a maximum 1” (25 mm) compound flow-out. Roll sheet into place, applying pressure with foot or roller on all laps immediately after rolling in. Apply extra pressure to avoid creating open channels, where three or more membranes are lapped.

BASE FLASHING: APP roof systems must be flashed according to All Weather APP Flashing Details (See Appendix).

SURFACING: Mineral surfacing requires the use of All Weather APP 190 Granulated or All Weather APP Glass Cap and specification number AWAG-2B-I-RG. Smooth surfacing utilizes All Weather APP 190 Smooth and specification number AWAS-2B-I-RG. Smooth surface APP must be coated with a roof coating. All reflective coatings require periodic recoating, which is the responsibility of the owner. The roof coating must be maintained in satisfactory condition to maintain the All Weather warranty coverage.

CAUTION: Application of APP membranes utilizes open flame from a torch. Improper use of a torch can result in physical injury as well as damage to property. Surfaces or structures which come in contact with the molten product or the open flame may catch fire or the applicator may suffer burns. Follow all local fire codes; have proper fire extinguishers in working condition, on the roof and readily available. See Safety Precautions/Considerations on page 20.

All Weather APP / 3 Ply System Over Existing Gravel Surface Roof

SPECIFICATION NOS: AWAG-AWAS-3B-I-RG

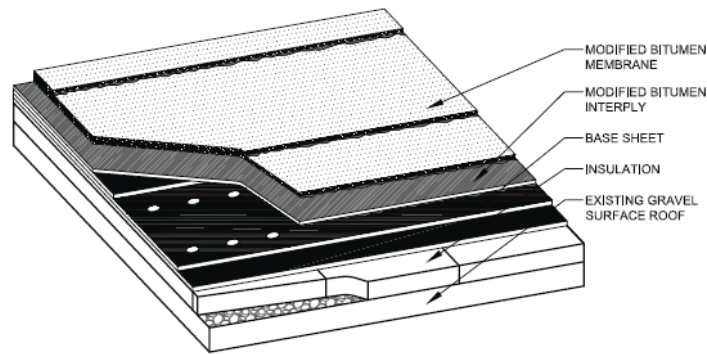

MATERIALS:

Approved Insulation¹ - As required
Mechanical Fasteners² - As required
Base Sheet³ - 1 Ply
APP Interply⁴ - 1 Ply
APP Membrane⁵ - 1 Ply

- 1 - Use insulation as approved by All Weather
- 2 - Use fasteners appropriate for deck type
- 3 - ASTM D 4601 Type II Base, USP® Base, USP® NVB
- 4 - All Weather APP 190 Smooth
- 5 - All Weather APP 190 Granulated

WARRANTY ELIGIBILITY:

All Weather Limited Material Warranty (no charge)

- All Weather APP 190 Smooth + All Weather APP 190 Granulated = 12 Year

IMPORTANT: BASE SHEET APPLICATION

Base sheets should be cut into lengths short enough to be easily handled and allowed to warm and relax prior to installation. Appropriate maximum membrane length will vary depending upon temperature conditions. The base sheet must be warmed to a temperature sufficient to allow expansion and relaxation of the asphaltic coating, prior to application, otherwise wrinkles may form. The applicator must evaluate weather conditions to determine maximum functional length and relaxation time to avoid wrinkling. Place tension on the end of the base sheet during installation to ensure that the sheet lays flat.

APPLICATION RECOMMENDATIONS

ROOF SUBSTRATE shall be swept, free of loose gravel and otherwise properly prepared prior to insulation installation.

ROOF INSULATION: shall be applied in approved manner. **Option 1:** Loose lay insulation with joints staggered in one direction over the existing roof for simultaneous base sheet attachment. **Option 2:** Mechanically fasten insulation through the existing roof to the deck with joints staggered in one direction.

BASE SHEET: **Option 1:** Select appropriate base sheet for deck type. Insulation and base sheet are fastened simultaneously. Mechanically fasten one ply of base sheet over the loose laid insulation. Lap sheets 2" (5 cm) on side laps and 4" (10 cm) on the end laps. Appropriate screws and plates are then installed per pattern determined by warranty requirements or by design criteria whichever is more stringent. Increase fastener density in perimeters and corners in accordance with project requirements. **Option 2:** Install base sheet, over insulation, in a uniform mopping of hot asphalt applied at the rate of 25 lb/square (1.2 kg/m²). Lap the sheets 2" (5 cm) on side laps and 4" (10 cm) on end laps.

APP INTERPLY MEMBRANE: Set and align rolls before application with at least 3" (7.6 cm) side laps and 6" (15.3 cm) end laps. Adjacent end laps shall be staggered 18" (45.7 cm). Apply sufficient heat, with a torch, to the back of the sheet to melt the asphalt to a semi-liquid state, while heating the base at the same time. A minimum of 3/8" (10 mm) compound flow-out must be obtained at all seam areas. Do not exceed a maximum 1" (25 mm) compound flow-out. Roll sheet into place, applying pressure with foot or roller on all laps immediately after rolling in. Apply extra pressure to avoid creating open channels, where three or more membranes are lapped.

APP MEMBRANE: Set and align rolls before application with at least 3" (7.6 cm) side laps and 6" (15.3 cm) end laps. Adjacent end laps shall be staggered 18" (45.7 cm). Stagger laps between the underlying ply and APP membrane. Apply sufficient heat, with a torch, to the back of the sheet to melt the asphalt to a semi-liquid state, while heating the base at the same time. A minimum of 3/8" (10 mm) compound flow-out must be obtained at all seam areas. Do not exceed a maximum 1" (25 mm) compound flow-out. Roll sheet into place, applying pressure with foot or roller on all laps immediately after rolling in. Apply extra pressure to avoid creating open channels, where three or more membranes are lapped.

BASE FLASHING: APP roof systems must be flashed according to All Weather APP Flashing Details (See Appendix).

CAUTION: Application of APP membranes utilizes open flame from a torch. Improper use of a torch can result in physical injury as well as damage to property. Surfaces or structures which come in contact with the molten product or the open flame may catch fire or the applicator may suffer burns. Follow all local fire codes; have proper fire extinguishers in working condition, on the roof and readily available. See Safety Precautions/Considerations on page 20.

**All Weather SBS / 2 Ply System
Nailable Deck / Lightweight Concrete Deck**

SPECIFICATION NOS: AWSG-2B-N, AWSG-2V-LWC

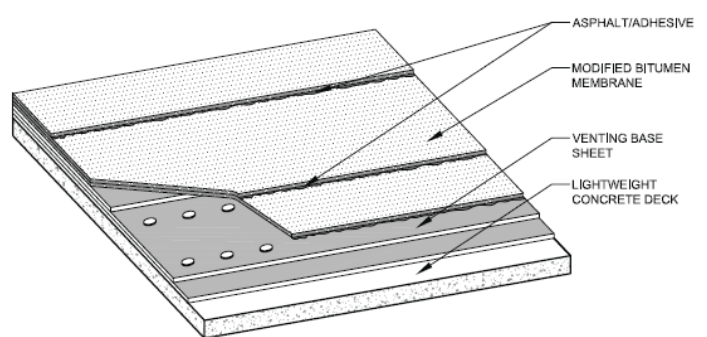
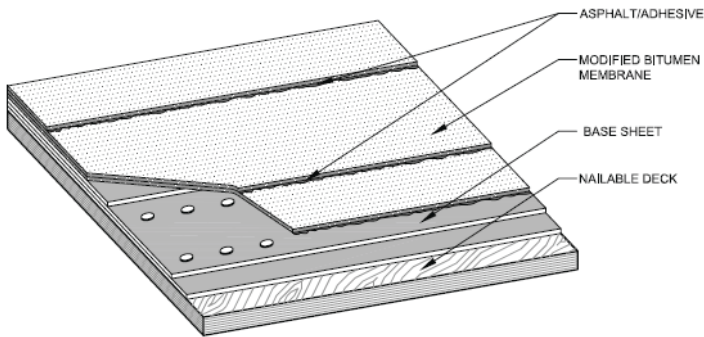

MATERIALS:

- Mechanical Fasteners¹ - As required
- Base Sheet² – 1 Ply
- SBS Membrane³ – 1 Ply

- ¹ - Use fasteners approved for deck type
- ² - ASTM D 4601 Type II Base, USP® Base, USP® NVB
- ³ - All Weather SBS #85 GM Fiberglass Cap, All Weather SBS 190 Granulated

WARRANTY ELIGIBILITY:

All Weather Limited Material Warranty (no charge)

- Base + All Weather SBS #85 GM Fiberglass Cap = 10 Year
- Base + All Weather SBS 190 Granulated = 12 Year

IMPORTANT: BASE SHEET APPLICATION

Base sheets should be cut into lengths short enough to be easily handled and allowed to warm and relax prior to installation. Appropriate maximum membrane length will vary depending upon temperature conditions. The base sheet must be warmed to a temperature sufficient to allow expansion and relaxation of the asphaltic coating, prior to application, otherwise wrinkles may form. The applicator must evaluate weather conditions to determine maximum functional length and relaxation time to avoid wrinkling. Place tension on the end of the base sheet during installation to ensure that the sheet lays flat.

APPLICATION RECOMMENDATIONS

ROOF DECK shall be firm, clean, dry and smooth. All membranes shall be applied so the flow of water is over or parallel to, but never against the laps.

BASE SHEET: Select appropriate base sheet for deck type. Mechanically fasten base sheet over the deck. Lap the base sheet a minimum of 2” (5.1 cm) of sides and 4” (10.2 cm) on ends, and mechanically fasten with appropriate fasteners. Follow pattern determined by warranty requirements or by design criteria whichever is more stringent. Increase fastener density in perimeters and corners in accordance with project requirements.

SBS MEMBRANE: Set and align rolls before application with at least 4” (10.2 cm) side laps and 6” (15.2 cm) end laps. Adjacent end laps shall be staggered 18” (45.7 cm) apart. Stagger laps between the base ply and SBS membrane. Install membrane in either cold adhesive or hot asphalt. Cold adhesive shall be applied at the rate of 1.5 – 2.0 gal per 100 sq. ft. (6 L/m² - 8 L/m²). Asphalt shall be applied at its EVT temperature or 425°F (218°C), whichever is greater, in a uniform layer, without voids, at a rate of 25 lb/square (1.2 kg/m²) ± 20%. A minimum of 3/8” (10 mm) adhesive/asphalt flow-out must be obtained at all seam areas. Do not exceed a maximum 2” (5.1 cm) asphalt flow-out. Ensure that the cap sheet lays flat in the adhesive/asphalt. There must be complete adhesion between the cap sheet and the adhesive/ asphalt. Brooming in may be necessary under certain conditions to insure that the cap sheet adheres solidly to the adhesive/asphalt. Apply extra pressure to avoid creating open channels, where three or more membranes are lapped. Check all seams for full and uniform adhesion. Dry laps are not acceptable. Lift all un-adhered seams with a trowel and reseal with USP® 954 Premium Modified Flashing Cement.

BASE FLASHING: SBS roof systems must be flashed according to All Weather SBS Flashing Details (See Appendix).

CAUTION: Application of SBS membranes utilizes hot asphalt. Always wear protective clothing as contact with molten product can result in physical injury or the applicator may suffer burns. Follow all local fire codes; have proper fire extinguishers in working condition, on the roof and readily available. See Safety Precautions/Considerations on page 20.

**All Weather SBS / 2 Ply System
Insulated Deck**
SPECIFICATION NO: **AWSG-2B-I**

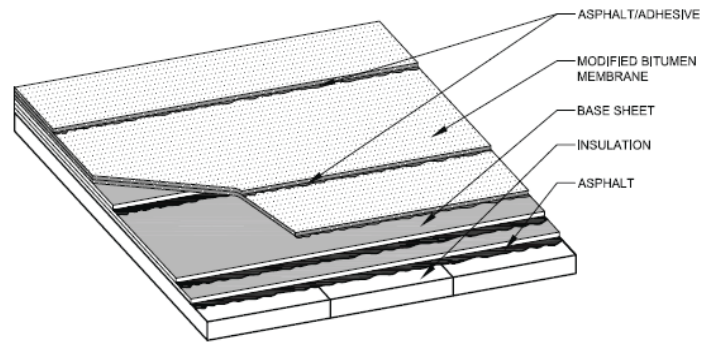
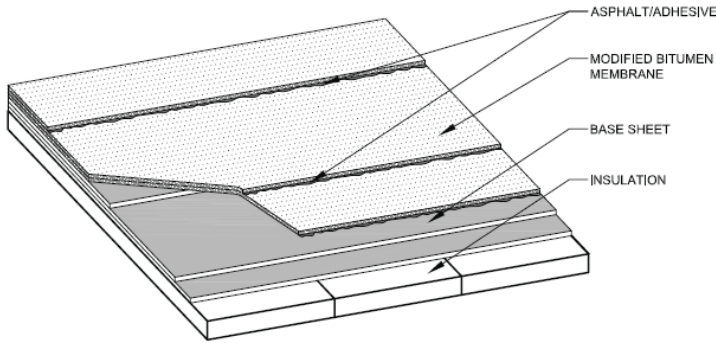

MATERIALS:

- Approved Insulation¹ – As required
 - Mechanical Fasteners² - As required
 - Base Sheet³ – 1 Ply
 - Roofing Asphalt⁴ – 25 lbs/square (1.2 kg/m²) per ply, or SBS Cold Adhesive @ 1.5 - 2.0 gal/square (0.6 – 0.8 L/ m²)
 - SBS Membrane⁵ – 1 Ply
- ¹ - Use insulation approved by U.S. Ply
 - ² - Use fasteners approved for deck type
 - ³ - ASTM D 4601 Type II Base, USP® Base, USP® NVB
 - ⁴ - ASTM D 312 Type III or IV Roofing Asphalt, USP® 901 Premium Modified Adhesive
 - ⁵ - All Weather SBS #85 GM Fiberglass Cap, All Weather SBS 190 Granulated

WARRANTY ELIGIBILITY:

All Weather Limited Material Warranty (no charge)

- Base + All Weather SBS #85 GM Fiberglass Cap = 10 Year
- Base + All Weather SBS 190 Granulated = 12 Year

APPLICATION RECOMMENDATIONS

ROOF DECK shall be firm, clean, dry and smooth. All membranes shall be applied so the flow of water is over or parallel to, but never against the laps.

WOOD INSULATION STOPS the same thickness as the insulation, shall be attached at outside edges and openings through the deck. These stops shall be 6” (15 cm) wide or 1” (25 mm) wider than flanges being nailed to them.

BASE SHEET: Option 1: Select appropriate base sheet for deck type. Insulation and base sheet are fastened simultaneously. Mechanically fasten one ply of base sheet over the loose laid insulation. Lap sheets 2” (5.1 cm) on side laps and 4” (10.2 cm) on the end laps. Appropriate screws and plates are then installed per pattern determined by warranty requirements or by design criteria whichever is more stringent. Increase fastener density in perimeters and corners in accordance with project requirements. **Option 2:** Install base sheet, over insulation, in a uniform mopping of hot asphalt applied at the rate of 25 lb/square (1.2 kg/m²). Lap the sheets 2” (5.1 cm) on side laps and 4” (10.2 cm) on end laps.

SBS MEMBRANE: Set and align rolls before application with at least 4” (10.2 cm) side laps and 6” (15.2 cm) end laps. Adjacent end laps shall be staggered 18” (45.7 cm) apart. Stagger laps between the base ply and SBS membrane. Install membrane in either cold adhesive or hot asphalt. Cold adhesive shall be applied at the rate of 1.5 – 2.0 gal per 100 sq. ft. (6 L/m² - 8 L/m²). Asphalt shall be applied at its EVT temperature or 425°F (218°C), whichever is greater, in a uniform layer, without voids, at a rate of 25 lb/square (1.2 kg/m²) ± 20%. A minimum of 3/8” (10 mm) adhesive/asphalt flow-out must be obtained at all seam areas. Do not exceed a maximum 2” (5.1 cm) asphalt flow-out. Ensure that the cap sheet lays flat in the adhesive/asphalt. There must be complete adhesion between the cap sheet and the adhesive/ asphalt. Brooming in may be necessary under certain conditions to insure that the cap sheet adheres solidly to the adhesive/asphalt. Apply extra pressure to avoid creating open channels, where three or more membranes are lapped. Check all seams for full and uniform adhesion. Dry laps are not acceptable. Lift all un-adhered seams with a trowel and reseal with USP® 954 Premium Modified Flashing Cement.

BASE FLASHING: SBS roof systems must be flashed according to All Weather SBS Flashing Details (See Appendix).

CAUTION: Application of SBS membranes utilizes hot asphalt. Always wear protective clothing as contact with molten product can result in physical injury or the applicator may suffer burns. Follow all local fire codes; have proper fire extinguishers in working condition, on the roof and readily available. See Safety Precautions/Considerations on page 20.

All Weather SBS / 2 Ply System Non-Nailable Deck / Concrete Deck

SPECIFICATION NO: AWSG-2B-NN

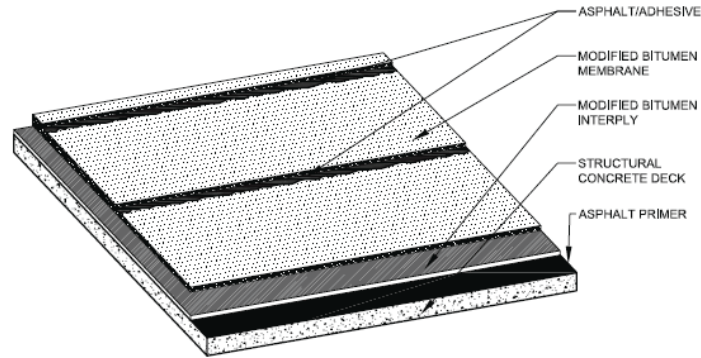

MATERIALS:

Asphalt Primer¹ - 1 gal/square (0.4 L/m²)

Roofing Asphalt² - 25 lbs/square (1.2 kg/m²) per ply

Base Sheet³ - 1 Ply

SBS Membrane⁴ - 1 Ply

- ¹ - ASTM D 41 Asphalt Primer
- ² - ASTM D 312 Type III or IV Roofing Asphalt, USP® 901 Premium Modified Adhesive
- ³ - ASTM D 4601 Type II Base, USP® Base, USP® NVB
- ⁴ - All Weather SBS #85 GM Fiberglass Cap, All Weather SBS 190 Granulated

WARRANTY ELIGIBILITY:

All Weather Limited Material Warranty (no charge)

- Base + All Weather SBS #85 GM Fiberglass Cap = 10 Year
- Base + All Weather SBS 190 Granulated = 12 Year

IMPORTANT: BASE SHEET APPLICATION

Base sheets should be cut into lengths short enough to be easily handled and allowed to warm and relax prior to installation. Appropriate maximum membrane length will vary depending upon temperature conditions. The base sheet must be warmed to a temperature sufficient to allow expansion and relaxation of the asphaltic coating, prior to application, otherwise wrinkles may form. The applicator must evaluate weather conditions to determine maximum functional length and relaxation time to avoid wrinkling. Place tension on the end of the base sheet during installation to ensure that the sheet lays flat.

APPLICATION RECOMMENDATIONS

ROOF DECK shall be firm, clean, dry and smooth. All membranes shall be applied so the flow of water is over or parallel to, but never against the laps.

PRIME the deck with asphalt primer applied at the rate of 1 gal/square (0.4 L/m²). Hold primer back 6" (15 cm) from concrete deck joints.

BASE SHEET: Select appropriate base sheet for deck type. Install base sheet, over the primed deck, in a uniform mopping of hot asphalt applied at the rate of 25 lb/square (1.2 kg/m²). Lap the sheets 2" (5.1 cm) on side laps and 4" (10.2 cm) on end laps.

SBS MEMBRANE: Set and align rolls before application with at least 4" (10.2 cm) side laps and 6" (15.2 cm) end laps. Adjacent end laps shall be staggered 18" (45.7 cm) apart. Stagger laps between the base ply and SBS membrane. Install membrane in either cold adhesive or hot asphalt. Cold adhesive shall be applied at the rate of 1.5 - 2.0 gal per 100 sq. ft. (6 L/m² - 8 L/m²). Asphalt shall be applied at its EVT temperature or 425°F (218°C), whichever is greater, in a uniform layer, without voids, at a rate of 25 lb/square (1.2 kg/m²) ± 20%. A minimum of 3/8" (10 mm) adhesive/asphalt flow-out must be obtained at all seam areas. Do not exceed a maximum 2" (5.1 cm) asphalt flow-out. Ensure that the cap sheet lays flat in the adhesive/asphalt. There must be complete adhesion between the cap sheet and the adhesive/asphalt. Brooming in may be necessary under certain conditions to insure that the cap sheet adheres solidly to the adhesive/asphalt. Apply extra pressure to avoid creating open channels, where three or more membranes are lapped. Check all seams for full and uniform adhesion. Dry laps are not acceptable. Lift all un-adhered seams with a trowel and reseal with USP® 954 Premium Modified Flashing Cement.

BASE FLASHING: SBS roof systems must be flashed according to All Weather SBS Flashing Details (See Appendix).

CAUTION: Application of SBS membranes utilizes hot asphalt. Always wear protective clothing as contact with molten product can result in physical injury or the applicator may suffer burns. Follow all local fire codes; have proper fire extinguishers in working condition, on the roof and readily available. See Safety Precautions/Considerations on page 20.

**All Weather SBS / 2 Ply System
Over Existing Smooth Surface Roof**
SPECIFICATION NO: AWSG-2B-RC

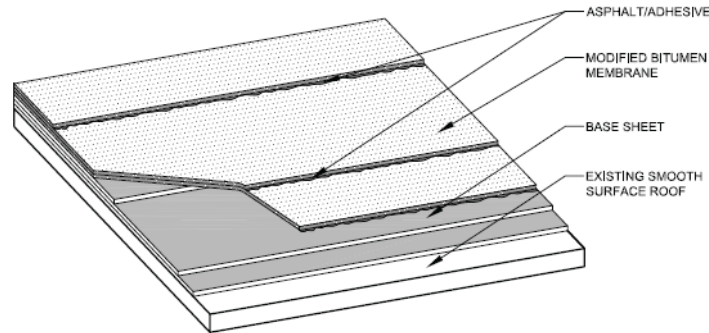

MATERIALS:

Mechanical Fasteners¹ – as required
Roofing Asphalt² – 25 lbs/square (1.2 kg/m²) per ply
Base Sheet³ – 1 Ply
SBS Membrane⁴ – 1 Ply

- 1 - Use fasteners approved for deck type
- 2 - ASTM D 312 Type III or IV Roofing Asphalt, USP® 901 Premium Modified Adhesive
- 3 - ASTM D 4601 Type II Base, USP® Base, USP® NVB
- 4 - All Weather SBS Glass Cap, All Weather SBS 190 Granulated

WARRANTY ELIGIBILITY:

All Weather Limited Material Warranty (no charge)

- Base + All Weather SBS #85 GM Fiberglass Cap = 10 Year
- Base + All Weather SBS 190 Granulated = 12 Year

APPLICATION RECOMMENDATIONS

ROOF SUBSTRATE shall be firm, clean, dry and smooth. All membranes shall be applied so the flow of water is over or parallel to, but never against the laps.

BASE SHEET: Select appropriate base sheet for deck type. Mechanically fasten base sheet over the deck. Lap the base sheet a minimum of 2” (5.1 cm) of sides and 4” (10.2 cm) on ends, and mechanically fasten with appropriate fasteners. Follow pattern determined by warranty requirements or by design criteria whichever is more stringent. Increase fastener density in perimeters and corners in accordance with project requirements.

SBS MEMBRANE: Set and align rolls before application with at least 4” (10.2 cm) side laps and 6” (15.2 cm) end laps. Adjacent end laps shall be staggered 18” (45.7 cm) apart. Stagger laps between the base ply and SBS membrane. Install membrane in either cold adhesive or hot asphalt. Cold adhesive shall be applied at the rate of 1.5 – 2.0 gal per 100 sq. ft. (6 L/m² - 8 L/m²). Asphalt shall be applied at its EVT temperature or 425°F (218°C), whichever is greater, in a uniform layer, without voids, at a rate of 25 lb/square (1.2 kg/m²) ± 20%. A minimum of 3/8” (10 mm) adhesive/asphalt flow-out must be obtained at all seam areas. Do not exceed a maximum 2” (5.1 cm) asphalt flow-out. Ensure that the cap sheet lays flat in the adhesive/asphalt. There must be complete adhesion between the cap sheet and the adhesive/asphalt. Brooming in may be necessary under certain conditions to insure that the cap sheet adheres solidly to the adhesive/asphalt. Apply extra pressure to avoid creating open channels, where three or more membranes are lapped. Check all seams for full and uniform adhesion. Dry laps are not acceptable. Lift all un-adhered seams with a trowel and reseal with USP® 954 Premium Modified Flashing Cement.

BASE FLASHING: SBS roof systems must be flashed according to All Weather SBS Flashing Details (See Appendix).

CAUTION: Application of SBS membrane utilizes hot asphalt. Always wear protective clothing as contact with molten product can result in physical injury or the applicator may suffer burns. Follow all local fire codes; have proper fire extinguishers in working condition, on the roof and readily available. See Safety Precautions/Considerations on page 20.

IMPORTANT: BASE SHEET APPLICATION

Base sheets should be cut into lengths short enough to be easily handled and allowed to warm and relax prior to installation. Appropriate maximum membrane length will vary depending upon temperature conditions. The base sheet must be warmed to a temperature sufficient to allow expansion and relaxation of the asphaltic coating, prior to application, otherwise wrinkles may form. The applicator must evaluate weather conditions to determine maximum functional length and relaxation time to avoid wrinkling. Place tension on the end of the base sheet during installation to ensure that the sheet lays flat.

All Weather SBS / 2 Ply System Over Existing Gravel Surfaced Roof

SPECIFICATION NO: AWSG-2B-I-RG

2

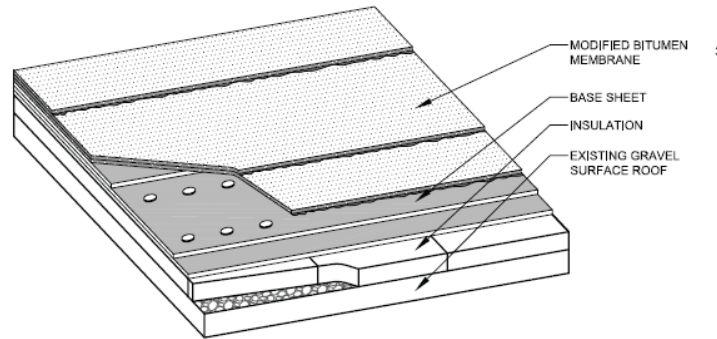

MATERIALS:

Approved Insulation¹ – As required

Mechanical Fasteners² - As required

Base Sheet³ – 1 Ply

Roofing Asphalt⁴ – 25 lbs/square (1.2 kg/m²) per ply, or SBS Cold Adhesive @ 1.5 - 2.0 gal/square (0.6 – 0.8 L/m²)

SBS Membrane⁵ – 1 Ply

- 1 - Use insulation approved by U.S. Ply
- 2 - Use fasteners approved for deck type
- 3 - ASTM D 4601 Type II Base, USP® Base, USP® NVB
- 4 - ASTM D 312 Type III or IV Roofing Asphalt, USP® 901 Premium Modified Adhesive
- 5 - All Weather SBS #85 GM Fiberglass Cap, All Weather SBS 190 Granulated

WARRANTY ELIGIBILITY:

All Weather Limited Material Warranty (no charge)

- Base + All Weather SBS #85 GM Fiberglass Cap = 10 Year
- Base + All Weather SBS 190 Granulated = 12 Year

IMPORTANT: BASE SHEET APPLICATION

Base sheets should be cut into lengths short enough to be easily handled and allowed to warm and relax prior to installation. Appropriate maximum membrane length will vary depending upon temperature conditions. The base sheet must be warmed to a temperature sufficient to allow expansion and relaxation of the asphaltic coating, prior to application, otherwise wrinkles may form. The applicator must evaluate weather conditions to determine maximum functional length and relaxation time to avoid wrinkling. Place tension on the end of the base sheet during installation to ensure that the sheet lays flat.

APPLICATION RECOMMENDATIONS

ROOF SUBSTRATE shall be swept, free of loose gravel and otherwise properly prepared prior to insulation installation.

ROOF INSULATION: shall be applied in approved manner. **Option 1:** Loose lay insulation with joints staggered in one direction over the existing roof for simultaneous base sheet attachment. **Option 2:** Mechanically fasten insulation through the existing roof to the deck with joints staggered in one direction.

BASE SHEET: Option 1: Select appropriate base sheet for deck type. Insulation and base sheet are fastened simultaneously. Mechanically fasten one ply of base sheet over the loose laid insulation. Lap sheets 2” (5.1 cm) on side laps and 4” (10.2 cm) on the end laps. Appropriate screws and plates are then installed per pattern determined by warranty requirements or by design criteria whichever is more stringent. Increase fastener density in perimeters and corners in accordance with project requirements. **Option 2:** Install base sheet, over insulation, in a uniform mopping of hot asphalt applied at the rate of 25 lb/square (1.2 kg/m²). Lap the sheets 2” (5.1 cm) on side laps and 4” (10.2 cm) on end laps.

SBS MEMBRANE: Set and align rolls before application with at least 4” (10.2 cm) side laps and 6” (15.2 cm) end laps. Adjacent end laps shall be staggered 18” (45.7 cm) apart. Stagger laps between the base ply and SBS membrane. Install membrane in either cold adhesive or hot asphalt. Cold adhesive shall be applied at the rate of 1.5 – 2.0 gal per 100 sq. ft. (6 L/m² - 8 L/m²). Asphalt shall be applied at its EVT temperature or 425°F (218°C), whichever is greater, in a uniform layer, without voids, at a rate of 25 lb/square (1.2 kg/m²) ± 20%. A minimum of 3/8” (10 mm) adhesive/asphalt flow-out must be obtained at all seam areas. Do not exceed a maximum 2” (5.1 cm) asphalt flow-out. Ensure that the cap sheet lays flat in the adhesive/asphalt. There must be complete adhesion between the cap sheet and the adhesive/asphalt. Brooming in may be necessary under certain conditions to insure that the cap sheet adheres solidly to the adhesive/asphalt. Apply extra pressure to avoid creating open channels, where three or more membranes are lapped. Check all seams for full and uniform adhesion. Dry laps are not acceptable. Lift all un-adhered seams with a trowel and reseal with USP® 954 Premium Modified Flashing Cement.

BASE FLASHING: SBS roof systems must be flashed according to All Weather SBS Flashing Details (See Appendix).

CAUTION: Application of SBS membrane utilizes hot asphalt. Always wear protective clothing as contact with molten product can result in physical injury or the applicator may suffer burns. Follow all local fire codes; have proper fire extinguishers in working condition, on the roof and readily available. See Safety Precautions/Considerations on page 20.

All Weather APP Flashing Details

Note: The details shown on these pages indicate the general method of installing All Weather APP membranes and flashing.

All Weather APP Detail 1

Perimeter Gravel Edge

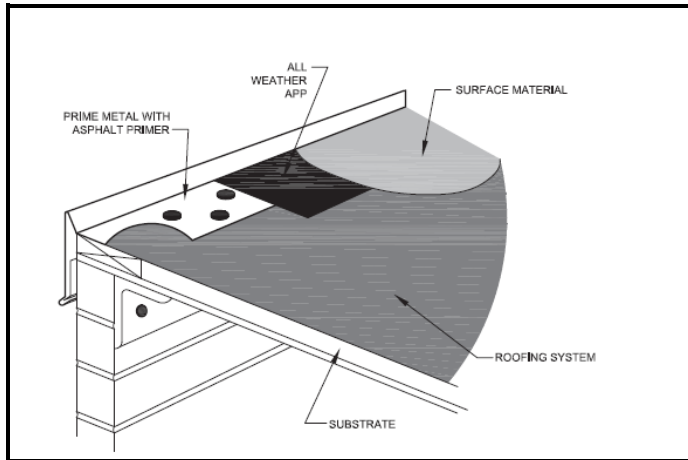

All Weather APP Detail 2

Perimeter Drip Edge

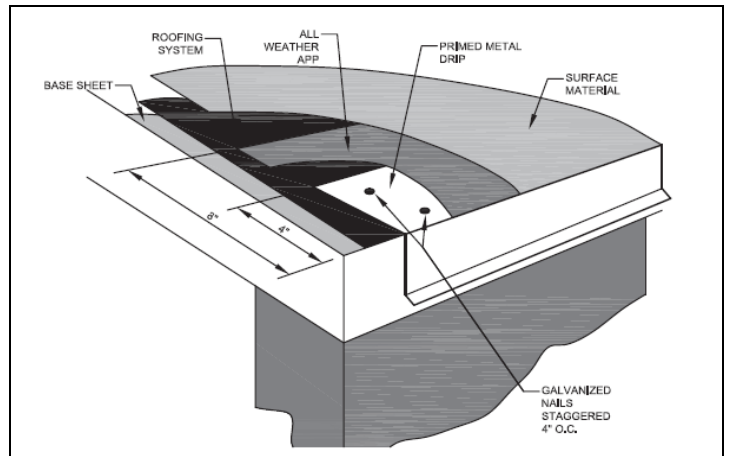

All Weather APP Detail 3

Parapet Wall Flashing (Wall height 24" and under)

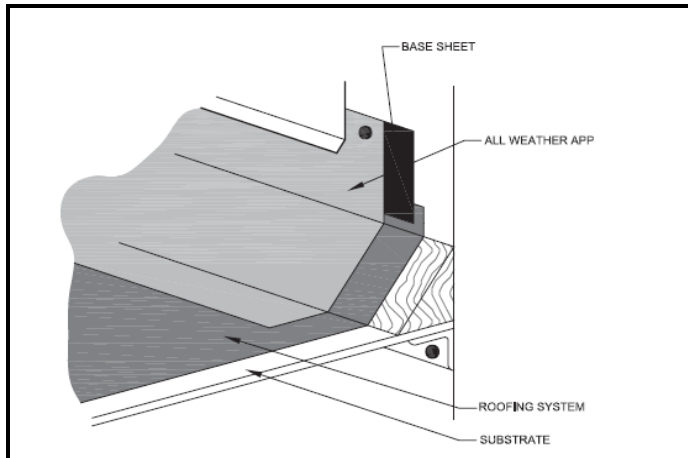

All Weather APP Detail 4

High Parapet Wall (Wall height over 24")

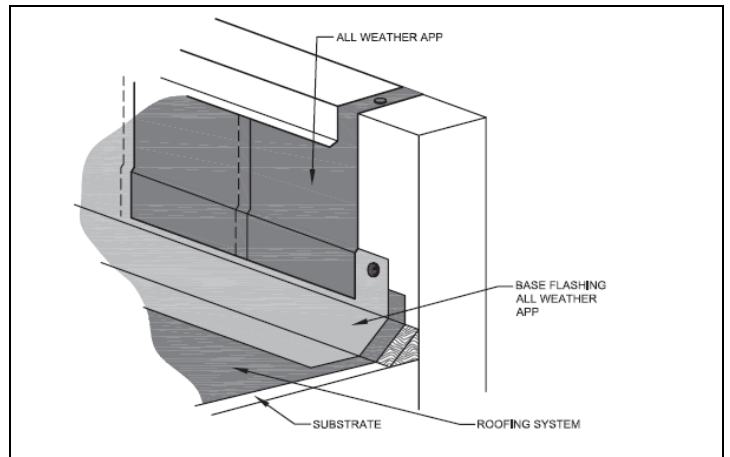

All Weather APP Detail 5

Roof Drain

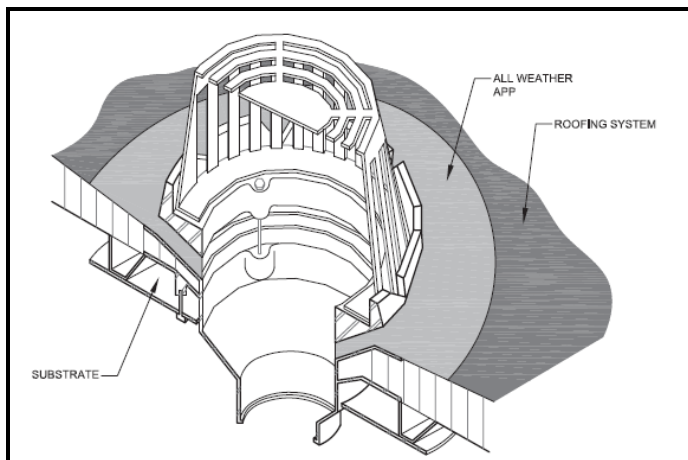

All Weather APP Detail 6

Pitch Pan Flashing

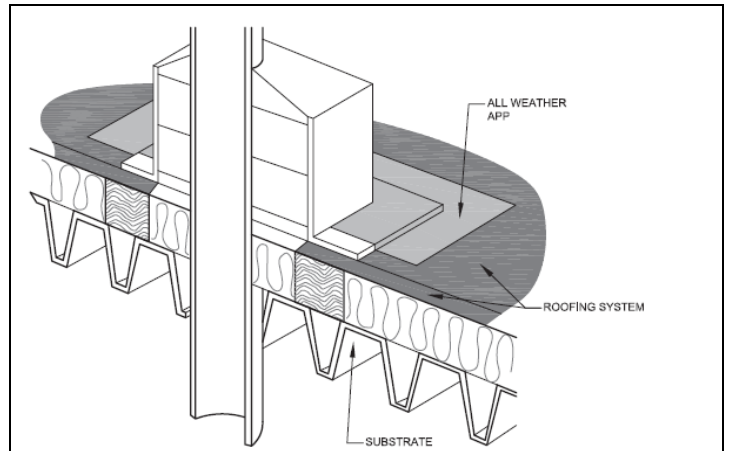

All Weather APP Detail 7

Pre-manufactured Curb Flashing and Roof Hatch

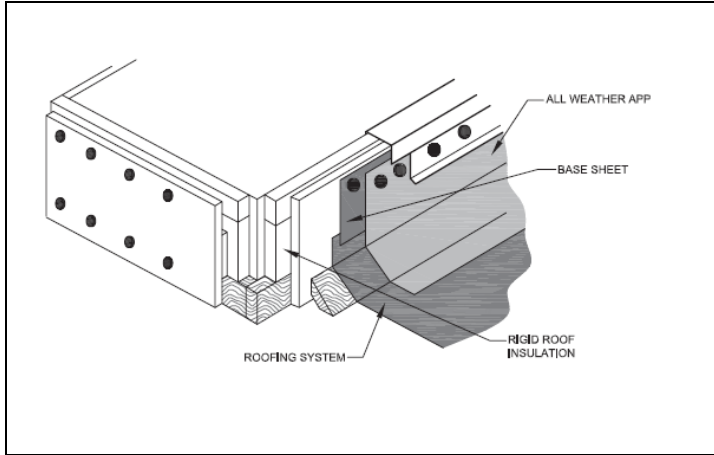

All Weather APP Detail 8

Expansion Joint

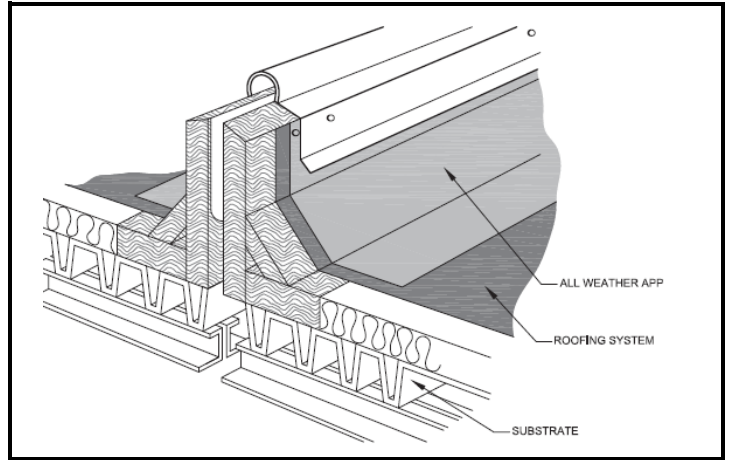

All Weather APP Detail 9

Vent Stack Flashing

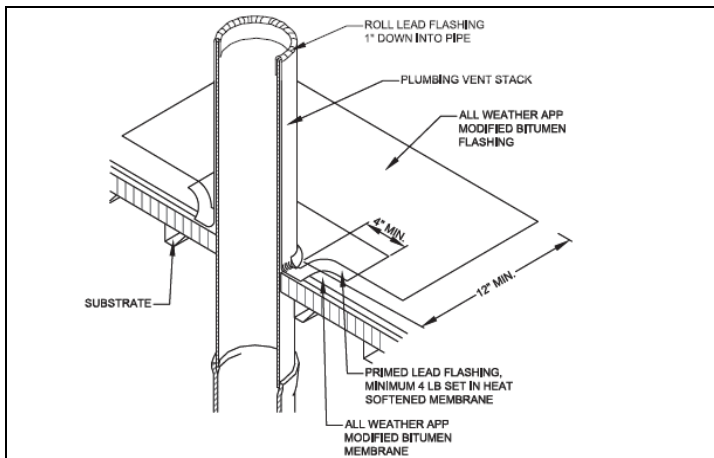

All Weather APP Detail 10

Roof Projection

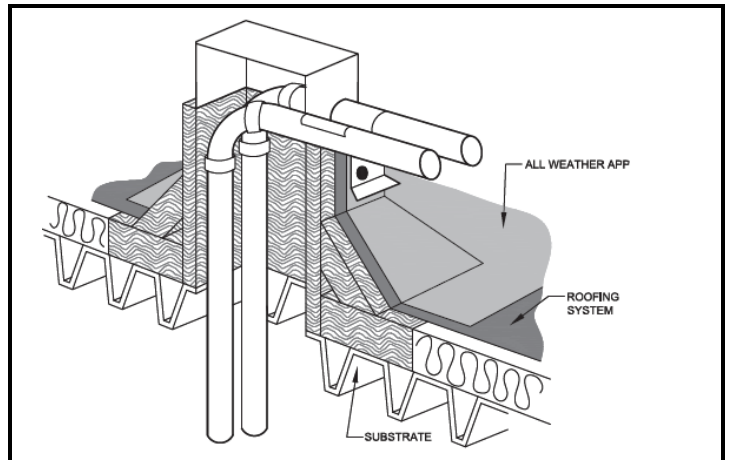

All Weather APP Detail 11

Scupper Flashing

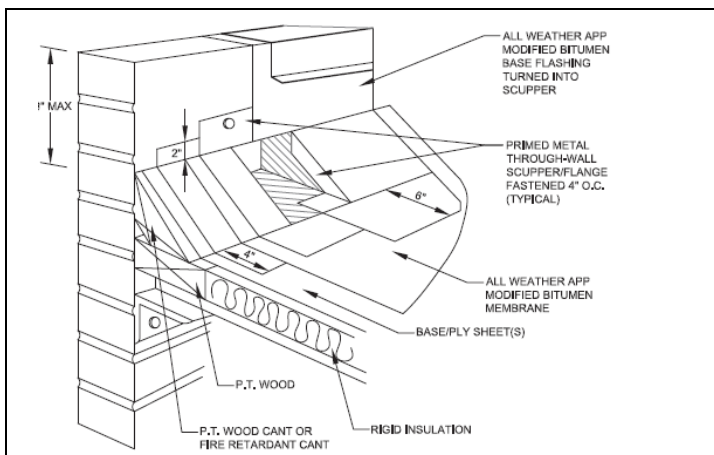

All Weather APP Detail 12

Flat Roof/Shingle Tie-in

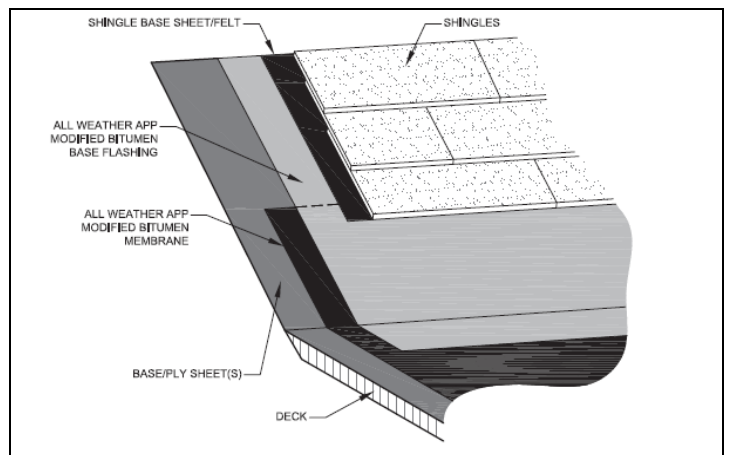

All Weather SBS Flashing Details

Note: The details shown on these pages indicate the general method of installing All Weather SBS membranes and flashing.

All Weather SBS Detail 1

Perimeter Gravel Edge

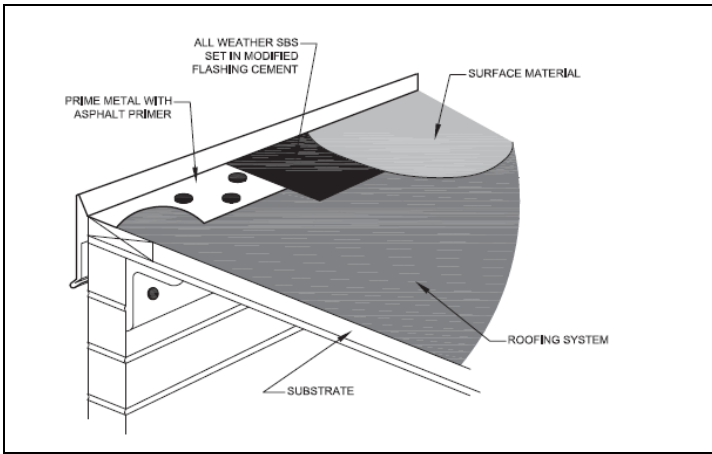

All Weather SBS Detail 2

Perimeter Drip Edge

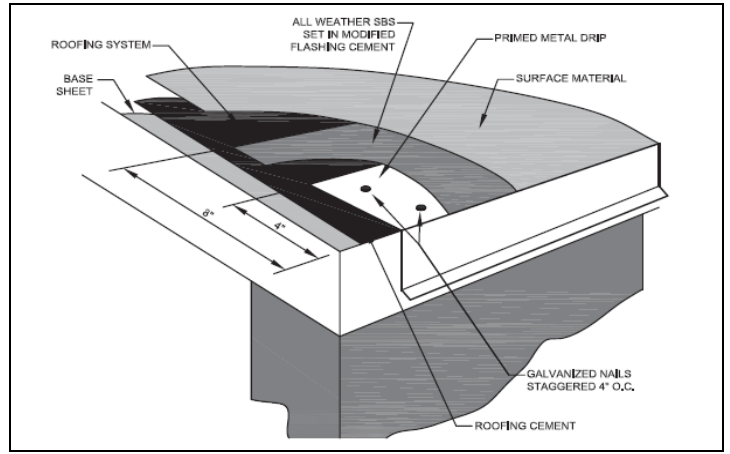

All Weather SBS Detail 3

Parapet Wall Flashing (Wall height 24" and under)

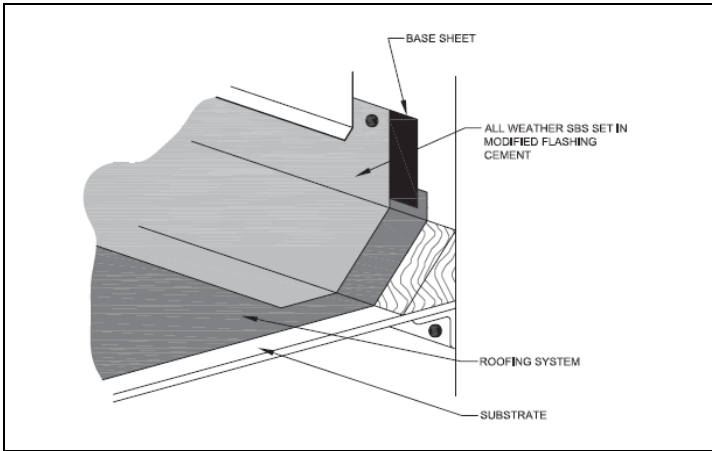

All Weather SBS Detail 4

High Parapet Wall (Wall height over 24")

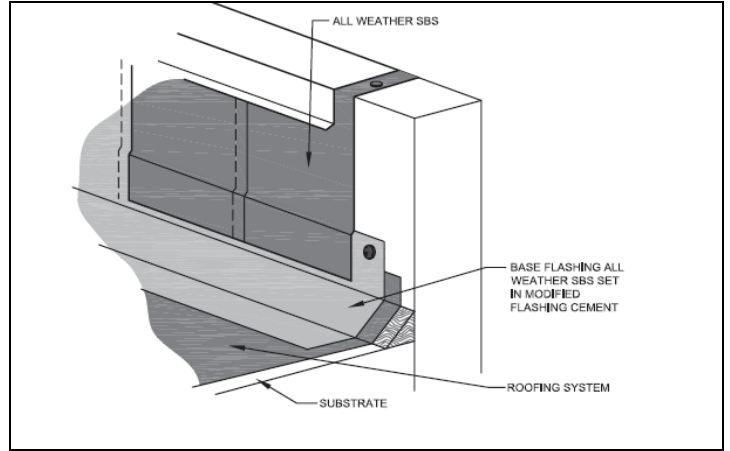

All Weather SBS Detail 5

Roof Drain

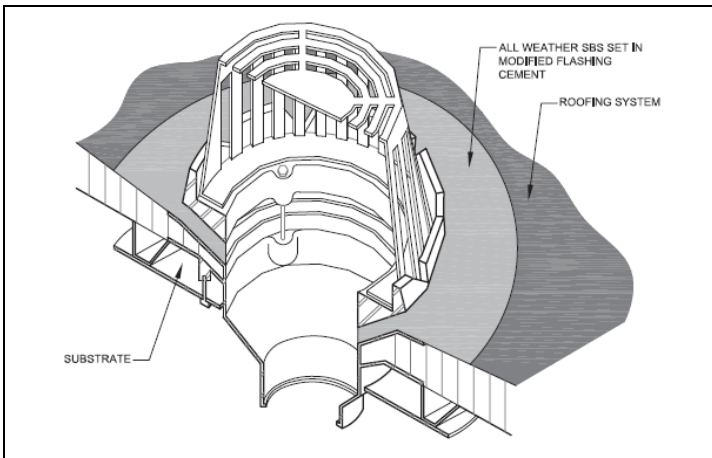

All Weather SBS Detail 6

Pitch Pan Flashing

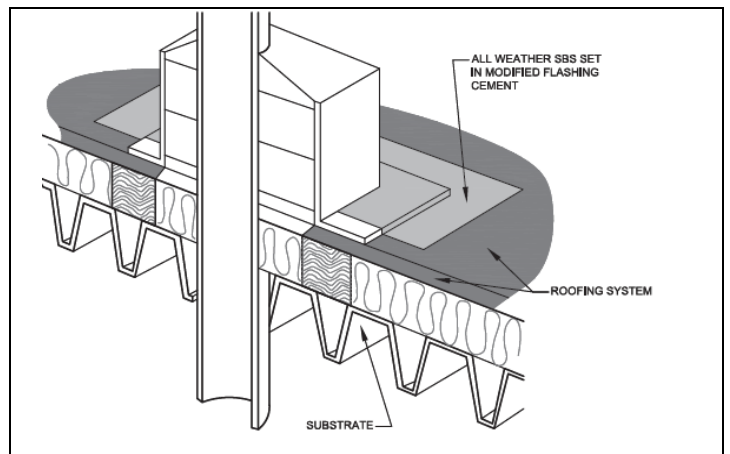

All Weather SBS Detail 7

Pre-manufactured Curb Flashing and Roof Hatch

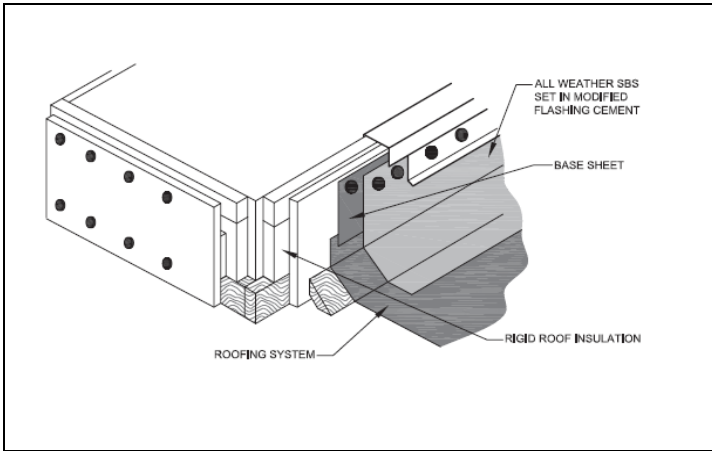

All Weather SBS Detail 8

Expansion Joint

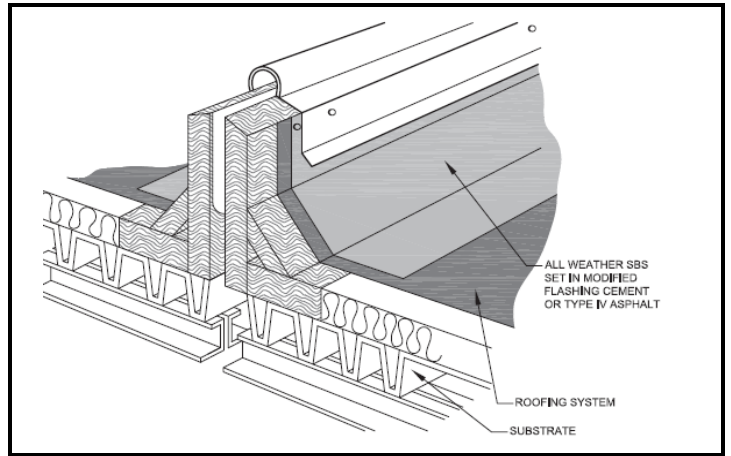

All Weather SBS Detail 9

Vent Stack Flashing

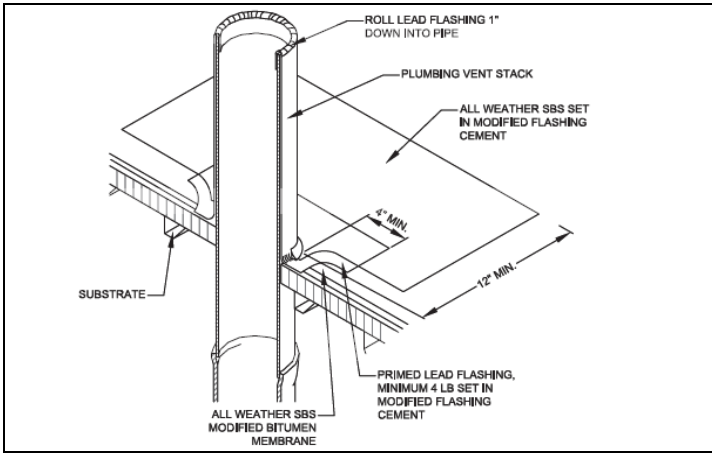

All Weather SBS Detail 10

Roof Projection

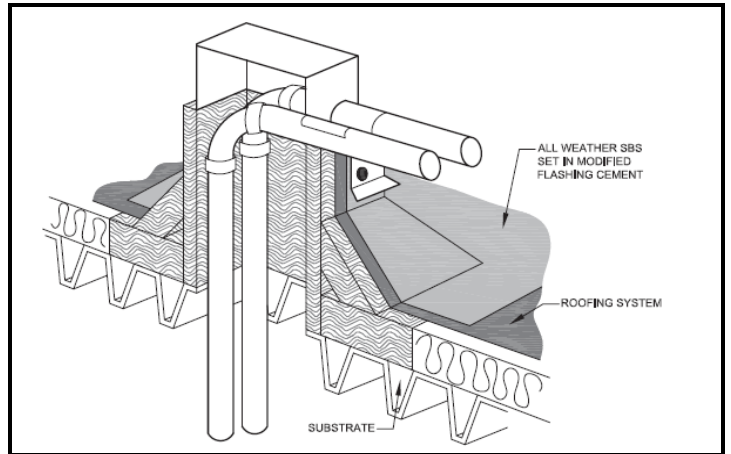

All Weather APP Detail 11

Scupper Flashing

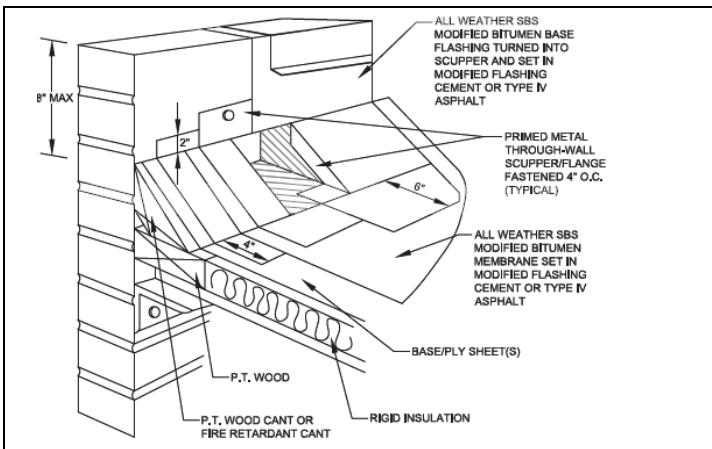

All Weather SBS Detail 12

Flat Roof/Shingle Tie-in

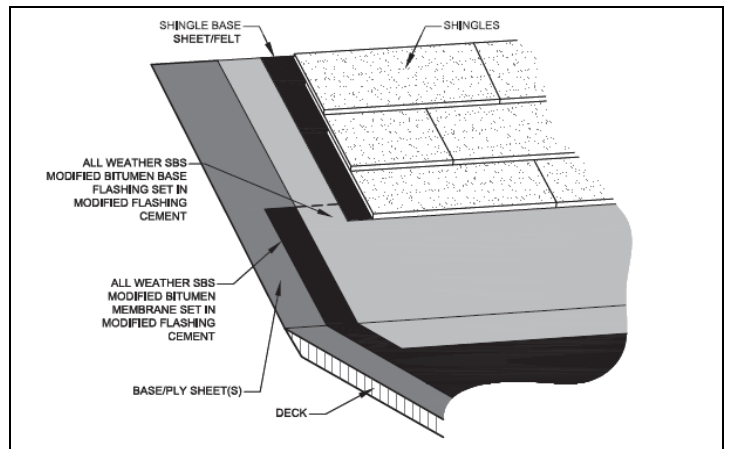



PROUDLY
MADE IN THE U.S.A.
BY U.S. PLY, INC.

CORPORATE HEADQUARTERS: P.O. BOX 1182, BRIDGEPORT, TEXAS 76426

PHONE: (817)413-0103 FAX: (817)413-8221

WWW.USPLY.COM